



University of the Philippines
OPEN UNIVERSITY

PHILIPPINE BIDDING DOCUMENTS

for

COMPLETION OF THE LOBBY AREA AND BREAKOUT ROOMS OF THE UPOU INTERNATIONAL CONVENTION CENTER

**Sixth Edition
July 2020**

Preface

These Philippine Bidding Documents (PBDs) for the procurement of Infrastructure Projects (hereinafter referred to also as the “Works”) through Competitive Bidding have been prepared by the Government of the Philippines for use by all branches, agencies, departments, bureaus, offices, or instrumentalities of the government, including government-owned and/or -controlled corporations, government financial institutions, state universities and colleges, local government units, and autonomous regional government. The procedures and practices presented in this document have been developed through broad experience, and are for mandatory use in projects that are financed in whole or in part by the Government of the Philippines or any foreign government/foreign or international financing institution in accordance with the provisions of the 2016 revised Implementing Rules and Regulations (IRR) of Republic Act (RA) No. 9184.

The PBDs are intended as a model for admeasurements (unit prices or unit rates in a bill of quantities) types of contract, which are the most common in Works contracting.

The Bidding Documents shall clearly and adequately define, among others: (i) the objectives, scope, and expected outputs and/or results of the proposed contract; (ii) the eligibility requirements of Bidders; (iii) the expected contract duration; and (iv) the obligations, duties, and/or functions of the winning Bidder.

Care should be taken to check the relevance of the provisions of the PBDs against the requirements of the specific Works to be procured. If duplication of a subject is inevitable in other sections of the document prepared by the Procuring Entity, care must be exercised to avoid contradictions between clauses dealing with the same matter.

Moreover, each section is prepared with notes intended only as information for the Procuring Entity or the person drafting the Bidding Documents. They shall not be included in the final documents. The following general directions should be observed when using the documents:

- a. All the documents listed in the Table of Contents are normally required for the procurement of Infrastructure Projects. However, they should be adapted as necessary to the circumstances of the particular Project.
- b. Specific details, such as the “*name of the Procuring Entity*” and “*address for bid submission*,” should be furnished in the Instructions to Bidders, Bid Data Sheet, and Special Conditions of Contract. The final documents should contain neither blank spaces nor options.
- c. This Preface and the footnotes or notes in italics included in the Invitation to Bid, BDS, General Conditions of Contract, Special Conditions of Contract, Specifications, Drawings, and Bill of Quantities are not part of the text of the final document, although they contain instructions that the Procuring Entity should strictly follow.

- d. The cover should be modified as required to identify the Bidding Documents as to the names of the Project, Contract, and Procuring Entity, in addition to date of issue.
- e. Modifications for specific Procurement Project details should be provided in the Special Conditions of Contract as amendments to the Conditions of Contract. For easy completion, whenever reference has to be made to specific clauses in the Bid Data Sheet or Special Conditions of Contract, these terms shall be printed in bold typeface on Sections I (Instructions to Bidders) and III (General Conditions of Contract), respectively.
- f. For guidelines on the use of Bidding Forms and the procurement of Foreign-Assisted Projects, these will be covered by a separate issuance of the Government Procurement Policy Board.

TABLE OF CONTENTS

Glossary of Terms, Abbreviations, and Acronyms	6
SECTION I. INVITATION TO BID FOR	8
SECTION II. INSTRUCTIONS TO BIDDERS	10
1. Scope of Bid.....	10
2. Funding Information	10
3. Bidding Requirements.....	10
4. Corrupt, Fraudulent, Collusive, Coercive, and Obstructive Practices	10
5. Eligible Bidders.....	11
6. Origin of Associated Goods	11
7. Subcontracts	11
8. Pre-Bid Conference.....	11
9. Clarification and Amendment of Bidding Documents.....	12
10. Documents Comprising the Bid: Eligibility and Technical Components	12
11. Documents Comprising the Bid: Financial Component	12
12. Alternative Bids	13
13. Bid Prices	13
14. Bid and Payment Currencies.....	13
15. Bid Security.....	13
16. Sealing and Marking of Bids.....	13
17. Deadline for Submission of Bids	14
18. Opening and Preliminary Examination of Bids	14
19. Detailed Evaluation and Comparison of Bids.....	14
20. Post Qualification.....	14
21. Signing of the Contract	15
SECTION III. BID DATA SHEET	16
SECTION IV. GENERAL CONDITIONS OF CONTRACT	18
1. Scope of Contract.....	18
2. Sectional Completion of Works	18
3. Possession of Site.....	18
4. The Contractor’s Obligations.....	18
5. Performance Security	19
6. Site Investigation Reports	19
7. Warranty.....	19

8. Liability of the Contractor.....	19
9. Termination for Other Causes.....	19
10. Dayworks	20
11. Program of Work.....	20
12. Instructions, Inspections and Audits	20
13. Advance Payment.....	20
14. Progress Payments	20
15. Operating and Maintenance Manuals.....	21
SECTION V. SPECIAL CONDITIONS OF CONTRACT	22
DIVISION 10 – SPECIALTIES	107
SECTION VII. DRAWINGS	109
SECTION VIII. BILL OF QUANTITIES	120
SECTION IX. CHECKLIST OF TECHNICAL AND FINANCIAL DOCUMENTS	127
STATEMENT OF ALL ONGOING GOVERNMENT & PRIVATE CONTRACTS INCLUDING CONTRACTS AWARDED BUT NOT YET STARTED.....	129
STATEMENT OF BIDDER’S SINGLE LARGEST COMPLETED CONTRACT (SLCC) SIMILAR TO THE CONTRACT TO BE BID	130
Bid Securing Declaration Form	131
Omnibus Sworn Statement (Revised).....	132
SECRETARY’S CERTIFICATE.....	134
SPECIAL POWER OF ATTORNEY	135
NET FINANCIAL CONTRACTING CAPACITY	136
JOINT VENTURE AGREEMENT	137
BID FORM	138
CONSTRUCTOR’S ORGANIZATIONAL CHART FOR THE CONTRACT	140
CONTRACTOR’S LETTER-CERTIFICATE TO PROCURING ENTITY..	141
QUALIFICATION OF KEY PERSONNEL PROPOSED TO BE ASSIGNED TO THE CONTRACT.....	142
BIO-DATA OF KEY PERSONNEL.....	143
KEY PERSONNEL’S CERTIFICATE OF EMPLOYMENT.....	145
CASH FLOW BY QUARTER AND PAYMENT SCHEDULE.....	149
SEALING AND MARKING OF BIDS:.....	151

Glossary of Terms, Abbreviations, and Acronyms

ABC – Approved Budget for the Contract.

ARCC – Allowable Range of Contract Cost.

BAC – Bids and Awards Committee.

Bid – A signed offer or proposal to undertake a contract submitted by a bidder in response to and in consonance with the requirements of the bidding documents. Also referred to as *Proposal* and *Tender*. (2016 revised IRR, Section 5[c])

Bidder – Refers to a contractor, manufacturer, supplier, distributor and/or consultant who submits a bid in response to the requirements of the Bidding Documents. (2016 revised IRR, Section 5[d])

Bidding Documents – The documents issued by the Procuring Entity as the bases for bids, furnishing all information necessary for a prospective bidder to prepare a bid for the Goods, Infrastructure Projects, and/or Consulting Services required by the Procuring Entity. (2016 revised IRR, Section 5[e])

BIR – Bureau of Internal Revenue.

BSP – Bangko Sentral ng Pilipinas.

CDA – Cooperative Development Authority.

Consulting Services – Refer to services for Infrastructure Projects and other types of projects or activities of the GOP requiring adequate external technical and professional expertise that are beyond the capability and/or capacity of the GOP to undertake such as, but not limited to: (i) advisory and review services; (ii) pre-investment or feasibility studies; (iii) design; (iv) construction supervision; (v) management and related services; and (vi) other technical services or special studies. (2016 revised IRR, Section 5[i])

Contract – Refers to the agreement entered into between the Procuring Entity and the Supplier or Manufacturer or Distributor or Service Provider for procurement of Goods and Services; Contractor for Procurement of Infrastructure Projects; or Consultant or Consulting Firm for Procurement of Consulting Services; as the case may be, as recorded in the Contract Form signed by the parties, including all attachments and appendices thereto and all documents incorporated by reference therein.

Contractor – is a natural or juridical entity whose proposal was accepted by the Procuring Entity and to whom the Contract to execute the Work was awarded. Contractor as used in these Bidding Documents may likewise refer to a supplier, distributor, manufacturer, or consultant.

CPI – Consumer Price Index.

DOLE – Department of Labor and Employment.

DTI – Department of Trade and Industry.

Foreign-funded Procurement or Foreign-Assisted Project – Refers to procurement whose funding source is from a foreign government, foreign or international financing institution as specified in the Treaty or International or Executive Agreement. (2016 revised IRR, Section 5[b]).

GFI – Government Financial Institution.

GOCC – Government-owned and/or –controlled corporation.

Goods – Refer to all items, supplies, materials and general support services, except Consulting Services and Infrastructure Projects, which may be needed in the transaction of public businesses or in the pursuit of any government undertaking, project or activity, whether in the nature of equipment, furniture, stationery, materials for construction, or personal property of any kind, including non-personal or contractual services such as the repair and maintenance of equipment and furniture, as well as trucking, hauling, janitorial, security, and related or analogous services, as well as procurement of materials and supplies provided by the Procuring Entity for such services. The term “related” or “analogous services” shall include, but is not limited to, lease or purchase of office space, media advertisements, health maintenance services, and other services essential to the operation of the Procuring Entity. (2016 revised IRR, Section 5[r])

GOP – Government of the Philippines.

Infrastructure Projects – Include the construction, improvement, rehabilitation, demolition, repair, restoration or maintenance of roads and bridges, railways, airports, seaports, communication facilities, civil works components of information technology projects, irrigation, flood control and drainage, water supply, sanitation, sewerage and solid waste management systems, shore protection, energy/power and electrification facilities, national buildings, school buildings, hospital buildings, and other related construction projects of the government. Also referred to as *civil works or works*. (2016 revised IRR, Section 5[u])

LGUs – Local Government Units.

NFCC – Net Financial Contracting Capacity.

NGA – National Government Agency.

PCAB – Philippine Contractors Accreditation Board.

PhilGEPS - Philippine Government Electronic Procurement System.

Procurement Project – refers to a specific or identified procurement covering goods, infrastructure project or consulting services. A Procurement Project shall be described, detailed, and scheduled in the Project Procurement Management Plan prepared by the agency which shall be consolidated in the procuring entity's Annual Procurement Plan. (GPPB Circular No. 06-2019 dated 17 July 2019)

PSA – Philippine Statistics Authority.

SEC – Securities and Exchange Commission.

SLCC – Single Largest Completed Contract.

UN – United Nations.



Section I. Invitation to Bid for

Completion of the Lobby Area and Breakout Rooms of the UPOU International Convention Center

The UP Open University (UPOU), through the Government of the Philippines (GOP) Revolving Fund, intends to apply the sum of **Five Million One Hundred Fourteen Thousand One Hundred Eighty-Three Pesos and Thirty-Three Centavos (PhP5,114,183.33)** being the Approved Budget for the Contract (ABC) to payments under the contract for **“Completion of the Lobby Area and Breakout Rooms of the UPOU International Convention Center”** (IB No. 25-01-001). Bids received in excess of the ABC shall be automatically rejected at bid opening.

The UPOU now invites bids for the above Procurement Project. Completion of the Works is required in forty-five (45) calendar days. Bidders should have completed a contract similar to the Project. The description of an eligible bidder is contained in the Bidding Documents, particularly, in Section II (Instructions to Bidders).

Bidding will be conducted through open competitive bidding procedures using non-discretionary *“pass/fail”* criterion as specified in the 2016 revised Implementing Rules and Regulations (IRR) of Republic Act (RA) No. 9184.

Interested bidders may obtain further information from BAC Secretariat and inspect the Bidding Documents from 8:00 AM to 5:00 PM Monday to Friday at the UPOU Headquarters, Los Baños, Laguna.

A complete set of Bidding Documents may be acquired by interested bidders from the address below and upon payment of the applicable fee for the Bidding Documents, pursuant to the latest Guidelines issued by the GPPB, in the amount of **Five Thousand Two Hundred Pesos (PhP 5,200.00)** only. UPOU shall allow the bidder to present its proof of payment for the fees in person, by facsimile or through electronic means.

The UPOU will hold a **Pre-Bid Conference on 16 January 2025, 2:00 PM** at the UPOU Headquarters, Los Baños, Laguna and/or through video conferencing or any other means, which shall be open to prospective bidders.

Bids must be duly received by the BAC Secretariat through manual submission at the office address indicated below **on or before 28 January 2025, 12:00 PM**. Late bids shall not be accepted.

All bids must be accompanied by a bid security in any of the acceptable forms and in the amount stated in **ITB** Clause 16.

Bid opening shall be on **28 January 2025, 2:00 PM** at the given address below and/or via video conferencing or any other means. Bids will be opened in the presence of the bidders' representatives who choose to attend the activity.

The UPOU reserves the right to reject any and all bids, declare a failure of bidding, or not award the contract at any time prior to contract award in accordance with Sections 35.6 and 41 of the 2016 revised Implementing Rules and Regulations (IRR) of RA No. 9184, without thereby incurring any liability to the affected bidder or bidders.

For further information, please refer to:

MS. ELVY A. PAMULAKLAKIN

Head, Bids and Awards Committee (BAC) Secretariat

UPOU Headquarters, Los Baños, Laguna

Telephone No.: (049) 536-6001-06 local 210-211

Telefax No.: (049) 536-5991

Email: **bac@upou.edu.ph**

You may visit the following websites:

For downloading of Bidding Documents:

<https://www.upou.edu.ph/bids-and-awards-committee/>

07 January 2025

(SGD) Dr. PRIMO G. GARCIA

Chair

Bids and Awards Committee

Section II. Instructions to Bidders

1. Scope of Bid

The UPOU invites Bids for the **Completion of the Lobby Area and Breakout Rooms of the UPOU International Convention Center**, with Project Identification Number IB No. 25-01-001.

The Procurement Project (referred to herein as “Project”) is for the construction of Works, as described in Section VI (Specifications).

2. Funding Information

2.1. The GOP through the source of funding as indicated below in the amount of PhP5,114,183.33.

2.2. The source of funding is Revolving Fund.

3. Bidding Requirements

The Bidding for the Project shall be governed by all the provisions of RA No. 9184 and its 2016 revised IRR, including its Generic Procurement Manual and associated policies, rules and regulations as the primary source thereof, while the herein clauses shall serve as the secondary source thereof.

Any amendments made to the IRR and other GPPB issuances shall be applicable only to the ongoing posting, advertisement, or invitation to bid by the BAC through the issuance of a supplemental or bid bulletin.

The Bidder, by the act of submitting its Bid, shall be deemed to have inspected the site, determined the general characteristics of the contracted Works and the conditions for this Project, such as the location and the nature of the work; (b) climatic conditions; (c) transportation facilities; (c) nature and condition of the terrain, geological conditions at the site communication facilities, requirements, location and availability of construction aggregates and other materials, labor, water, electric power and access roads; and (d) other factors that may affect the cost, duration and execution or implementation of the contract, project, or work and examine all instructions, forms, terms, and project requirements in the Bidding Documents.

4. Corrupt, Fraudulent, Collusive, Coercive, and Obstructive Practices

The Procuring Entity, as well as the Bidders and Contractors, shall observe the highest standard of ethics during the procurement and execution of the contract. They or through an agent shall not engage in corrupt, fraudulent, collusive, coercive, and obstructive practices defined under Annex “I” of the 2016 revised IRR of RA No. 9184 or other integrity violations in competing for the Project.

5. Eligible Bidders

- 5.1. Only Bids of Bidders found to be legally, technically, and financially capable will be evaluated.
- 5.2. The Bidder must have an experience of having completed a Single Largest Completed Contract (SLCC) that is similar to this Project, equivalent to at least fifty percent (50%) of the ABC adjusted, if necessary, by the Bidder to current prices using the PSA's CPI, except under conditions provided for in Section 23.4.2.4 of the 2016 revised IRR of RA No. 9184.

A contract is considered to be "similar" to the contract to be bid if it has the major categories of work stated in the **BDS**.

- 5.3. For Foreign-funded Procurement, the Procuring Entity and the foreign government/foreign or international financing institution may agree on another track record requirement, as specified in the Bidding Document prepared for this purpose.
- 5.4. The Bidders shall comply with the eligibility criteria under Section 23.4.2 of the 2016 IRR of RA No. 9184.

6. Origin of Associated Goods

There is no restriction on the origin of Goods other than those prohibited by a decision of the UN Security Council taken under Chapter VII of the Charter of the UN.

7. Subcontracts

- 7.1. The Bidder may subcontract portions of the Project to the extent allowed by the Procuring Entity as stated herein, but in no case more than fifty percent (50%) of the Project.

The Procuring Entity has prescribed that Subcontracting is not allowed.

- 7.2. Subcontracting of any portion of the Project does not relieve the Contractor of any liability or obligation under the Contract. The Supplier will be responsible for the acts, defaults, and negligence of any subcontractor, its agents, servants, or workmen as fully as if these were the Contractor's own acts, defaults, or negligence, or those of its agents, servants, or workmen.

8. Pre-Bid Conference

The Procuring Entity will hold a pre-bid conference for this Project on the specified date and time and either at its physical address, **UPOU Headquarters, Los Banos, Laguna** and/or through videoconferencing/webcasting as indicated in paragraph 6 of the **IB**.

9. Clarification and Amendment of Bidding Documents

Prospective bidders may request for clarification on and/or interpretation of any part of the Bidding Documents. Such requests must be in writing and received by the Procuring Entity, either at its given address or through electronic mail indicated in the **IB**, at least ten (10) calendar days before the deadline set for the submission and receipt of Bids.

10. Documents Comprising the Bid: Eligibility and Technical Components

- 10.1. The first envelope shall contain the eligibility and technical documents of the Bid as specified in **Section VIII. Checklist of Technical and Financial Documents**.
- 10.2. If the eligibility requirements or statements, the bids, and all other documents for submission to the BAC are in foreign language other than English, it must be accompanied by a translation in English, which shall be authenticated by the appropriate Philippine foreign service establishment, post, or the equivalent office having jurisdiction over the foreign bidder's affairs in the Philippines. For Contracting Parties to the Apostille Convention, only the translated documents shall be authenticated through an apostille pursuant to GPPB Resolution No. 13-2019 dated 23 May 2019. The English translation shall govern, for purposes of interpretation of the bid.
- 10.3. A valid PCAB License is required, and in case of joint ventures, a valid special PCAB License, and registration for the type and cost of the contract for this Project. Any additional type of Contractor license or permit shall be indicated in the **BDS**.
- 10.4. A List of Contractor's key personnel (e.g., Project Manager, Project Engineers, Materials Engineers, and Foremen) assigned to the contract to be bid, with their complete qualification and experience data shall be provided. These key personnel must meet the required minimum years of experience set in the **BDS**.
- 10.5. A List of Contractor's major equipment units, which are owned, leased, and/or under purchase agreements, supported by proof of ownership, certification of availability of equipment from the equipment lessor/vendor for the duration of the project, as the case may be, must meet the minimum requirements for the contract set in the **BDS**.

11. Documents Comprising the Bid: Financial Component

- 11.1. The second bid envelope shall contain the financial documents for the Bid as specified in **Section VIII. Checklist of Technical and Financial Documents**.
- 11.2. Any bid exceeding the ABC indicated in paragraph 1 of the **IB** shall not be accepted.

- 11.3. For Foreign-funded procurement, a ceiling may be applied to bid prices provided the conditions are met under Section 31.2 of the 2016 revised IRR of RA No. 9184.

12. Alternative Bids

Bidders shall submit offers that comply with the requirements of the Bidding Documents, including the basic technical design as indicated in the drawings and specifications. Unless there is a value engineering clause in the **BDS**, alternative Bids shall not be accepted.

13. Bid Prices

All bid prices for the given scope of work in the Project as awarded shall be considered as fixed prices, and therefore not subject to price escalation during contract implementation, except under extraordinary circumstances as determined by the NEDA and approved by the GPPB pursuant to the revised Guidelines for Contract Price Escalation guidelines.

14. Bid and Payment Currencies

14.1. Bid prices may be quoted in the local currency or tradeable currency accepted by the BSP at the discretion of the Bidder. However, for purposes of bid evaluation, Bids denominated in foreign currencies shall be converted to Philippine currency based on the exchange rate as published in the BSP reference rate bulletin on the day of the bid opening.

14.2. Payment of the contract price shall be made in Philippine Pesos.

15. Bid Security

15.1. The Bidder shall submit a Bid Securing Declaration or any form of Bid Security in the amount indicated in the **BDS**, which shall be not less than the percentage of the ABC in accordance with the schedule in the **BDS**.

15.2. The Bid and bid security shall be valid and shall not exceed one hundred twenty (120) calendar days from the date of the opening of bids. Any bid not accompanied by an acceptable bid security shall be rejected by the Procuring Entity as non-responsive.

16. Sealing and Marking of Bids

Each Bidder shall submit one copy of the first and second components of its Bid.

The Procuring Entity may request additional hard copies and/or electronic copies of the Bid. However, failure of the Bidders to comply with the said request shall not be a ground for disqualification.

If the Procuring Entity allows the submission of bids through online submission to the given website or any other electronic means, the Bidder shall submit an electronic copy of its Bid, which must be digitally signed. An electronic copy that cannot be opened or is corrupted shall be considered non-responsive and, thus, automatically disqualified.

17. Deadline for Submission of Bids

The Bidders shall submit on the specified date and time and either at its physical address or through online submission as indicated in paragraph 7 of the **IB**.

18. Opening and Preliminary Examination of Bids

18.1. The BAC shall open the Bids in public at the time, on the date, and at the place specified in paragraph 9 of the **IB**. The Bidders' representatives who are present shall sign a register evidencing their attendance. In case videoconferencing, webcasting or other similar technologies will be used, attendance of participants shall likewise be recorded by the BAC Secretariat.

In case the Bids cannot be opened as scheduled due to justifiable reasons, the rescheduling requirements under Section 29 of the 2016 revised IRR of RA No. 9184 shall prevail.

18.2. The preliminary examination of Bids shall be governed by Section 30 of the 2016 revised IRR of RA No. 9184.

19. Detailed Evaluation and Comparison of Bids

1. The Procuring Entity's BAC shall immediately conduct a detailed evaluation of all Bids rated "*passed*" using non-discretionary pass/fail criteria. The BAC shall consider the conditions in the evaluation of Bids under Section 32.2 of 2016 revised IRR of RA No. 9184.
2. If the Project allows partial bids, all Bids and combinations of Bids as indicated in the **BDS** shall be received by the same deadline and opened and evaluated simultaneously so as to determine the Bid or combination of Bids offering the lowest calculated cost to the Procuring Entity. Bid Security as required by **ITB** Clause 16 shall be submitted for each contract (lot) separately.
3. In all cases, the NFCC computation pursuant to Section 23.4.2.6 of the 2016 revised IRR of RA No. 9184 must be sufficient for the total of the ABCs for all the lots participated in by the prospective Bidder.

20. Post Qualification

Within a non-extendible period of five (5) calendar days from receipt by the Bidder of the notice from the BAC that it submitted the Lowest Calculated Bid, the Bidder shall submit its latest income and business tax returns filed and paid through the BIR Electronic Filing and Payment System (eFPS), and other appropriate licenses and permits required by law and stated in the **BDS**.

21. Signing of the Contract

The documents required in Section 37.2 of the 2016 revised IRR of RA No. 9184 shall form part of the Contract. Additional Contract documents are indicated in the **BDS**.

Section III. Bid Data Sheet

ITB Clause															
5.2	For this purpose, contracts similar to the Project refer to contracts which have the same major categories of work.														
7.1	<i>No additional requirement.</i>														
10.3	<i>No further instructions.</i>														
10.4	<p>The key personnel must meet the required minimum years of experience set below:</p> <table border="1" style="width: 100%; border-collapse: collapse;"> <thead> <tr> <th style="text-align: center;">Key Personnel</th> <th style="text-align: center;">General Experience</th> </tr> </thead> <tbody> <tr> <td>1. Project Architect/Civil Engineer (with valid license)</td> <td>Min. 5 yrs</td> </tr> <tr> <td>2. Safety Officer/Engineer</td> <td>Min. 5 yrs w/ COSH Certificate</td> </tr> <tr> <td>3. General Foreman</td> <td>Min. 5 yrs</td> </tr> </tbody> </table> <p>Note: Personnel with multiple expertise and qualifications with at most two different positions mentioned above are allowed as long as he/she can provide the necessary documentation in support of his/her qualifications such as appropriate valid licenses, certificate of training, accreditation, and the like should be submitted separately for each position.</p>	Key Personnel	General Experience	1. Project Architect/Civil Engineer (with valid license)	Min. 5 yrs	2. Safety Officer/Engineer	Min. 5 yrs w/ COSH Certificate	3. General Foreman	Min. 5 yrs						
Key Personnel	General Experience														
1. Project Architect/Civil Engineer (with valid license)	Min. 5 yrs														
2. Safety Officer/Engineer	Min. 5 yrs w/ COSH Certificate														
3. General Foreman	Min. 5 yrs														
10.5	<p>The minimum major equipment requirements are the following:</p> <table border="1" style="width: 100%; border-collapse: collapse;"> <thead> <tr> <th style="text-align: center;">A. Equipment</th> <th style="text-align: center;">No. of Units</th> </tr> </thead> <tbody> <tr> <td>1. Grinder</td> <td>Min. 2 units</td> </tr> <tr> <td>2. Tile Cutter</td> <td>Min. 2 units</td> </tr> <tr> <td>3. Welding Machine</td> <td>Min. 2 units</td> </tr> <tr> <td>4. Compressor</td> <td>Min. 1 unit</td> </tr> </tbody> </table> <table border="1" style="width: 100%; border-collapse: collapse;"> <thead> <tr> <th style="text-align: center;">B. Others</th> <th style="text-align: center;">No. of Units</th> </tr> </thead> <tbody> <tr> <td>1. PPE (Personal Protective Equipment) (includes hard hat, safety vest, safety shoes, safety harness, safety gloves)</td> <td>Min. of 15pcs per item except safety harness (5pcs only)</td> </tr> </tbody> </table>	A. Equipment	No. of Units	1. Grinder	Min. 2 units	2. Tile Cutter	Min. 2 units	3. Welding Machine	Min. 2 units	4. Compressor	Min. 1 unit	B. Others	No. of Units	1. PPE (Personal Protective Equipment) (includes hard hat, safety vest, safety shoes, safety harness, safety gloves)	Min. of 15pcs per item except safety harness (5pcs only)
A. Equipment	No. of Units														
1. Grinder	Min. 2 units														
2. Tile Cutter	Min. 2 units														
3. Welding Machine	Min. 2 units														
4. Compressor	Min. 1 unit														
B. Others	No. of Units														
1. PPE (Personal Protective Equipment) (includes hard hat, safety vest, safety shoes, safety harness, safety gloves)	Min. of 15pcs per item except safety harness (5pcs only)														
12	<i>No further instructions.</i>														
15.1	<p>The bid security shall be in the form of a Bid Securing Declaration or any of the following forms and amounts:</p> <ol style="list-style-type: none"> a. The amount of not less than PhP102,283.67 (2%) of ABC, if bid security is in cash, cashier's/manager's check, bank draft/guarantee or irrevocable letter of credit; b. The amount of not less than PhP255,709.17 (5%) of ABC if bid security is in Surety Bond. 														
19.2	Partial bids is not allowed.														
20	Valid PCAB License and Registration: Small B (min. size range); General Building (GB1); Category C or D (min. license category)														

21	The Bidder shall submit additional contract document relevant to the project such as Contractor's Letter-Certificate to UPOU.
----	---

Section IV. General Conditions of Contract

1. Scope of Contract

This Contract shall include all such items, although not specifically mentioned, that can be reasonably inferred as being required for its completion as if such items were expressly mentioned herein. All the provisions of RA No. 9184 and its 2016 revised IRR, including the Generic Procurement Manual, and associated issuances, constitute the primary source for the terms and conditions of the Contract, and thus, applicable in contract implementation. Herein clauses shall serve as the secondary source for the terms and conditions of the Contract.

This is without prejudice to Sections 74.1 and 74.2 of the 2016 revised IRR of RA No. 9184 allowing the GPPB to amend the IRR, which shall be applied to all procurement activities, the advertisement, posting, or invitation of which were issued after the effectivity of the said amendment.

2. Sectional Completion of Works

If sectional completion is specified in the **Special Conditions of Contract (SCC)**, references in the Conditions of Contract to the Works, the Completion Date, and the Intended Completion Date shall apply to any Section of the Works (other than references to the Completion Date and Intended Completion Date for the whole of the Works).

3. Possession of Site

3.1 The Procuring Entity shall give possession of all or parts of the Site to the Contractor based on the schedule of delivery indicated in the **SCC**, which corresponds to the execution of the Works. If the Contractor suffers delay or incurs cost from failure on the part of the Procuring Entity to give possession in accordance with the terms of this clause, the Procuring Entity's Representative shall give the Contractor a Contract Time Extension and certify such sum as fair to cover the cost incurred, which sum shall be paid by Procuring Entity.

3.2 If possession of a portion is not given by the above date, the Procuring Entity will be deemed to have delayed the start of the relevant activities. The resulting adjustments in contract time to address such delay may be addressed through contract extension provided under Annex "E" of the 2016 revised IRR of RA No. 9184.

4. The Contractor's Obligations

The Contractor shall employ the key personnel named in the Schedule of Key Personnel indicating their designation, in accordance with **ITB** Clause 10.3 and specified in the **BDS**, to carry out the supervision of the Works.

The Procuring Entity will approve any proposed replacement of key personnel only if their relevant qualifications and abilities are equal to or better than those of the personnel listed in the Schedule.

5. Performance Security

- 5.1. Within ten (10) calendar days from receipt of the Notice of Award from the Procuring Entity but in no case later than the signing of the contract by both parties, the successful Bidder shall furnish the performance security in any of the forms prescribed in Section 39 of the 2016 revised IRR.
- 5.2. The Contractor, by entering into the Contract with the Procuring Entity, acknowledges the right of the Procuring Entity to institute action pursuant to RA No. 3688 against any subcontractor be they an individual, firm, partnership, corporation, or association supplying the Contractor with labor, materials and/or equipment for the performance of this Contract.

6. Site Investigation Reports

The Contractor, in preparing the Bid, shall rely on any Site Investigation Reports referred to in the SCC supplemented by any information obtained by the Contractor.

7. Warranty

- 7.1. In case the Contractor fails to undertake the repair works under Section 62.2.2 of the 2016 revised IRR, the Procuring Entity shall forfeit its performance security, subject its property(ies) to attachment or garnishment proceedings, and perpetually disqualify it from participating in any public bidding. All payables of the GOP in his favor shall be offset to recover the costs.
- 7.2. The warranty against Structural Defects/Failures, except that occasioned-on force majeure, shall cover the period from the date of issuance of the Certificate of Final Acceptance by the Procuring Entity. Specific duration of the warranty is found in the SCC.

8. Liability of the Contractor

Subject to additional provisions, if any, set forth in the SCC, the Contractor's liability under this Contract shall be as provided by the laws of the Republic of the Philippines.

If the Contractor is a joint venture, all partners to the joint venture shall be jointly and severally liable to the Procuring Entity.

9. Termination for Other Causes

Contract termination shall be initiated in case it is determined *prima facie* by the Procuring Entity that the Contractor has engaged, before, or during the implementation of the contract, in unlawful deeds and behaviors relative to contract acquisition and implementation, such as, but not limited to corrupt, fraudulent, collusive, coercive, and obstructive practices as stated in **ITB** Clause 4.

10. Dayworks

Subject to the guidelines on Variation Order in Annex “E” of the 2016 revised IRR of RA No. 9184, and if applicable as indicated in the SCC, the Dayworks rates in the Contractor’s Bid shall be used for small additional amounts of work only when the Procuring Entity’s Representative has given written instructions in advance for additional work to be paid for in that way.

11. Program of Work

11.1. The Contractor shall submit to the Procuring Entity’s Representative for approval the said Program of Work showing the general methods, arrangements, order, and timing for all the activities in the Works. The submissions of the Program of Work are indicated in the SCC.

11.2. The Contractor shall submit to the Procuring Entity’s Representative for approval an updated Program of Work at intervals no longer than the period stated in the SCC. If the Contractor does not submit an updated Program of Work within this period, the Procuring Entity’s Representative may withhold the amount stated in the SCC from the next payment certificate and continue to withhold this amount until the next payment after the date on which the overdue Program of Work has been submitted.

12. Instructions, Inspections and Audits

The Contractor shall permit the GOP or the Procuring Entity to inspect the Contractor’s accounts and records relating to the performance of the Contractor and to have them audited by auditors of the GOP or the Procuring Entity, as may be required.

13. Advance Payment

The Procuring Entity shall, upon a written request of the Contractor which shall be submitted as a Contract document, make an advance payment to the Contractor in an amount not exceeding fifteen percent (15%) of the total contract price, to be made in lump sum, or at the most two installments according to a schedule specified in the SCC, subject to the requirements in Annex “E” of the 2016 revised IRR of RA No. 9184.

14. Progress Payments

The Contractor may submit a request for payment for Work accomplished. Such requests for payment shall be verified and certified by the Procuring Entity’s Representative/Project Engineer. Except as otherwise stipulated in the SCC, materials and equipment delivered on the site but not completely put in place shall not be included for payment.

15. Operating and Maintenance Manuals

- 15.1. If required, the Contractor will provide “as built” Drawings and/or operating and maintenance manuals as specified in the **SCC**.
- 15.2. If the Contractor does not provide the Drawings and/or manuals by the dates stated above, or they do not receive the Procuring Entity’s Representative’s approval, the Procuring Entity’s Representative may withhold the amount stated in the **SCC** from payments due to the Contractor.

Section V. Special Conditions of Contract

GCC Clause	
2	The Intended Completion Date is forty-five (45) calendar days from the starting date; the starting date being seven (7) calendar days from the issuance of the Notice to Proceed. NOTE: The contract duration shall be reckoned from the start date and not from contract effectivity date.
4.1	The UPOU shall give possession of all parts of the Site to the Contractor upon issuance of the Notice to Proceed.
6	The site inspection report shall be provided to the UPOU.
7.2	The warranty against Structural Defects/Failures, except those occasioned-on force majeure, shall cover a period of five (5) years.
10	No dayworks are applicable to the contract.
11.1	The Contractor shall submit the Schedule of Work to the Procuring Entity’s Representative within ten (10) calendar days of delivery of the Notice of Award.
11.2	The amount to be withheld for late submission of an updated Program of Work is one tenth (1/10) of one percent (1%) per day of delay for the current progress billing.
13	The amount of the advance payment is fifteen percent (15%) of the total contract price subject to the requirements of the Revised IRR of RA 9184 and additional conditions, if any.
14	Materials and equipment delivered on the site but not completely put in place shall not be included for payment.
15.1	(a) The date by which operating and maintenance manuals are required is not later than thirty (30) calendar days prior to conducting the acceptance test. (b) The date by which “as built” drawings are required is thirty (30) calendar days upon the project completion. (c) In addition, for every Progress of Work the contractor must submit an “As-Built” drawings as supporting document for the approval of Progress Payment.
15.2	The amount to be withheld for failing to produce “as built” drawings and/or operating and maintenance manuals by the date required is two percent (2%) of the Contract Price or the non-issuance of the Retention Money.

Section VI. Specifications

TECHNICAL SPECIFICATIONS

GENERAL REQUIREMENTS

1. This specification is intended to cover all labor and materials for the complete construction of all proposed projects as shown in the working drawing and described therein.
2. Materials and/or work not specifically mentioned in the specification, working drawings and other Contract Documents, but is implied and deemed necessary to complete the work shall be supplied by the Contractor, and executed in a work-manlike manner of appropriate number, location, size and the highest quality available without extra cost to the Owner.
3. The Owner reserves the right to alter and/or to omit any part of the plans, any extra charge must be submitted to the Architect and/or Engineer for approval of final acceptance.
4. The Contractor shall furnish for approval of the authorized representative with promptness, samples as specified or required work shall be in accordance with approved samples.
5. The Contractor shall guarantee the building except for works with specific guarantee for a period of one (1) year after the final acceptance by the Owner. He shall repair, replace and make good at his expense, all defects which may arise during the term of guarantee and warranty due to defective workmanship and/or inferior quality of materials.
6. All contractors submitting the proposal for this project shall first examine the site. All proposals shall take into consideration all such conditions that may affect the work under this contract. The specifications and plans shall form part as one. Anything mentioned on plans and not mentioned on the scope of work and specifications and vice versa shall be properly consulted to the Project Architect/Engineer for clarification.
7. The contractor shall coordinate his work with all parties to ensure proper phasing or comply with the approved schedule of work. The contractor shall engage under him, a registered Engineer or Architect to supervise his work. He shall remain at all times in the construction site.
8. Logbook shall be available at the site. It shall contain the daily activities in the site, including but not limited to weather condition, delivery, manpower and other matters pertaining to the condition of the project. It will also serve as the data for the contractor and the Project Inspector and shall be surrendered to the UPOU at the end of the project.
9. No alteration or additional work that will result in an additive or deductive cost change from the Contract shall be allowed without the approval of the chancellor.
10. The contractor shall submit at least three (3) options per item for approval. Complete specifications with product samples shall be submitted by the contractor to the Project

Architect and end-user for evaluation. Inspection of the Project Architect/Engineer in-charge shall be required prior to installation of any item/material on the construction.

11. Existing conditions of the work site shall be documented by the contractor and photos shall be taken before commencement of work to ensure such status. Any damage to the areas due to the contractor's on-going work shall be restored at his expense.

12. The contractor shall provide a complete copy of "As built plans" of the project/unit concerned in A3 original sheets, if necessary.

13. The contractor shall promptly remove from the premises all rubbish, trash, debris, and all superfluous building materials weekly. After the completion of all works, restore all areas that were damaged as affected by the construction works and leave the site clean to the satisfaction of the Project Inspector or his representative and End-user.

14. All materials removed from the unit shall be properly documented prior to turn-over to the End-user for proper safe keeping. The turn-over document shall be attached to the contractor's final billing.

ARCHITECTURAL WORKS

Architectural Works shall include the following provisions complete for the construction of building requirements in accordance to Specifications, Contract Drawings and applicable Codes and Standards:

- A. Steel doors with security and protective treatments complete with framing and hardware for intended uses as required.
- B. Ceiling, wall and floor finishes for interior and exterior applications, painting works, stone works, and accentuations as required.
- C. Toilet and bath accessories

Any item, material, labors not specifically included herein but are deemed necessary component for the execution of the works cited, such item must be included without additional time and cost component.

END OF SECTION

SECTION 03 53 00

CONCRETE TOPPING

PART 1 GENERAL

1.1 RELATED DOCUMENTS

Drawings and general provisions of the Contract, including General and Supplementary Conditions and Division 01 Specification Sections, apply to this Section.

1.2 SUMMARY

1.2.1 Section includes concrete floor toppings. Extent of concrete floor toppings is shown on Drawings and in schedules.

1.2.2 Types of concrete floor toppings include:

- a. Standard aggregate toppings.
- b. Repair of concrete surfaces as necessary to receive finished materials.
- c. Repair of holes less than 4 inches diameter and cracks in concrete slabs.

1.3 REFERENCES

1.3.1 Comply with requirements of Section 03 30 00 "Cast-in-Place Concrete" and as herein specified.

1.4 SUBMITTALS

1.4.1 Furnish data, samples, laboratory test reports, and materials certificates as specified in Section 03 30 00 "Cast-In-Place Concrete."

PART 2 PRODUCTS

2.1 CEMENT AND AGGREGATES

2.1.1 Portland Cement: ASTM C 150, Type I or III.

2.1.2 Normal Weight Aggregate: ASTM C 33 and as follows:

Fine aggregate, consisting of sand or crushed stone screenings, clean, hard, free from deleterious matter. Grade by weight to pass sieves as follows:

- a. 3/8 inch: 100 percent.
- b. No. 4: 95-100 percent.
- c. No. 8: 80-90 percent.
- d. No. 16: 50-75 percent.
- e. No. 30: 30-50 percent.
- f. No. 50: 10-20 percent.
- g. No. 100: 2-5 percent.

2.1.3 Manufacturer: Subject to compliance with requirements, provide factory pre-mixed topping mix with at least ten (10) years of experience in the industry:

2.1.4 Furnish selected aggregates to match the Owner's finish sample.

2.2 TOPPING MIX

2.2.1 Standard Topping: Design mix to produce topping material with the following characteristics:

- a. Compressive Strength: 3500 psi at 28 days.
- b. Slump: 8 inches maximum at point of placement for concrete containing high range water reducing admixture (super-plasticizer) and 3 inches maximum for other concrete.
- c. Maximum W/C Ratio: 0.51

2.3 MIXING

2.3.1 Provide a batch type mechanical mixer for mixing topping material at the Project site. Equip a batch mixer with a suitable charging hopper, water storage tank, and a water measuring device. Use only mixers that are capable of mixing aggregates, cement, and water into a uniform mix within specified time, and of discharging mix without segregation.

2.3.2 Mix each batch of 2 cu. yds. or less for at least 1-1/2 minutes after ingredients are in the mixer. Increase mixing time 15 seconds for each additional cup. yd. or fraction thereof.

2.3.3 Ready-mixed topping may be used when acceptable to Owner. When acceptable,

PART 3 EXECUTION

3.1 CONDITION OF SURFACES

3.1.1 Topping Applied to Fresh Concrete: Do not begin placement of topping until water ceases to rise to surface, and water and laitance have been removed from base slab surface.

3.1.2 Topping Applied to Hardened Concrete: Remove dirt, loose material, oil, grease, paint, or other contaminants, leaving a clean surface.

3.1.3 When the base slab surface is unacceptable for good bonding, roughen the surface by chipping or scarifying before cleaning. Prior to placing the topping mixture, thoroughly dampen the slab surface but do not leave standing water. Over a dampened surface, apply specified bonding compound (rewettable or non-re-wettable) or epoxy adhesive. Place topping mix after the rewettable bonding compound has dried or while the non-re-wettable bonding compound or epoxy adhesive is still tacky.

3.1.4 For reinforced toppings, provide necessary supports, and maintain the position of reinforcing mesh as shown on Drawings.

- 3.1.5 Joints: Mark locations of joints in base slab so that joints in top course will be placed directly over them.

3.2 PLACING AND FINISHING

- 3.2.1 Float Finish: Spread topping mixture evenly over prepared base to the required elevation and strike off. Use highway straightedge, bull float, or darby to level the surface. After the topping has stiffened sufficiently to permit the operation, and water sheen has disappeared, float the surface at least twice to a uniform sandy texture. Re-straighten where necessary with the highway straight edge. The surface shall achieve an F(F) 20/F(L) 17 tolerance when tested in accordance with ASTM E 1155. Uniformly slope surface to drains.
- 3.2.2 Where joints are required, construct to match and coincide with joints in the base slab. Provide other joints as shown.
- 3.2.3 Trowel Finish: After floating, consolidate concrete surface by final hand trowelling operations, free of trowel marks, uniform in texture and appearance, and with a surface plane tolerance not exceeding 1/8 inch in 10 feet when tested with a 10 foot straight edge.
- 3.2.4 Fill air holes, pits, and other blemishes with cement grout of same materials as used for topping. Spread grout over surface and work into openings with a steel straight edge.

3.3 CURING PROTECTION

Cure and protect topping applications and finishes.

3.4 PERFORMANCE

Failure of concrete topping to bond to substrate (as evidenced by a hollow sound when tapped), or disintegration or other failure of topping to perform as a floor finish, will be considered failure of materials and workmanship. Repair or replace toppings in areas of such failures, as directed.

END OF SECTION

SECTION 03 60 00

GROUTING

PART 1 GENERAL

1.1 RELATED DOCUMENTS

- 1.1.1 Drawings and general provisions of the Subcontract apply to this Section.
- 1.1.2 Review these documents for coordination with additional requirements and information that applies to work under this Section.

1.2 REFERENCES

1.2.1 General:

- a. The following documents form part of the Specifications to the extent stated. Where differences exist between codes and standards, the one affording the greatest protection shall apply.
- b. Unless otherwise noted, the referenced standard edition is the current one at the time of commencement of the Work.
- c. Refer to Division 01 Section "General Requirements" for the list of applicable regulatory requirements.

1.2.2 ASTM International:

- a. ASTM C33 Concrete Aggregates
- b. ASTM C40 Organic Impurities in Fine Aggregates for Concrete
- c. ASTM C88 Soundness of Aggregates by Use of Sodium Sulfate or Magnesium Sulfate
- d. ASTM C117 Material Finer Than 75 μ m Sieve in Mineral Aggregates by Washing
- e. ASTM C136 Sieve Analysis of Fine and Coarse Aggregates
- f. ASTM C150 Portland Cement
- g. ASTM C289 Potential Reactivity of Aggregates (Chemical Method)
- h. ASTM C494 Chemical Admixtures for Concrete
- i. ASTM C881 Epoxy-Resin-Base Bonding Systems for Concrete
- j. ASTM D2419 Sand Equivalent Value of Soils and Fine Aggregate
- k. ASTM E329 Inspection and Testing Agencies for Concrete, Steel, Bituminous Materials as Used in Construction

1.3 SUBMITTALS

1.3.1 Submit under provisions of Division 01 Section "General Requirements."

1.3.2 Manufacturer's data shall be provided for [bonding compounds] [pressure grout] [retardants].

1.3.3 Test reports, accompanied by a manufacturer's statement that previously tested material is of similar type, quality, and manufacture as that which is proposed for use on this projects, shall be submitted for:

- a. Cement.

- b. Aggregates.
- c. Retardants.
- d. Bonding compounds.

1.3.4 The subcontractor's testing laboratory shall provide evidence of the most recent inspection of its facilities by the Cement and Concrete Reference Laboratory of the National Bureau of Standards and evidence of correction of deficiencies noted in the inspection report before materials specified in this section are delivered to the job site.

1.4 QUALITY ASSURANCE

Conformance with the specified requirements will be demonstrated by testing performed by an independent testing laboratory.

PART 2 PRODUCTS

2.1 MATERIALS

2.1.1 Cement: Portland cement shall be ASTM C150 Type II or Type V, containing less than 0.6 percent alkali.

2.1.2 Aggregate:

a. General: Aggregate shall be non-reactive and shall be washed before use. When sources of aggregate are changed, test reports shall be provided for the material from the new source prior to commencing grout work.

b. Fine Aggregate: Fine aggregate shall be sand or crushed stone conforming to ASTM C33 as modified herein. When tested in accordance with ASTM C136, gradation shall be such that 100 percent by weight passes a standard No. 8 sieve and not less than 45 percent by weight pass a standard No. 40 sieve. Variation from the specified gradation in individual tests will be accepted if the average of three consecutive tests is within the following variation:

Standard Sieve	Permissible variation in individual test
No. 30 or coarser	2 percent by weight
No. 50 or finer	0.5 percent by weight

2.1.3 Admixtures:

a. General: Admixtures shall be compatible with the grout and shall comply with the manufacturer's recommendations. Admixtures shall be added to the grout mix separately.

b. Water Reducing Retarder: Water reducing retarder shall comply with ASTM C494, Type D.

c. Lubricant

2.1.4 Water:

Water for washing aggregate, for mixing and for curing shall be potable, shall not contain more than 1000 mg/l of chlorides as Cl, nor more than 1300 mg/l of sulfates as SO₄, and shall not contain impurities which may change the setting time by more than 25 percent or a reduction of more than 5 percent of the compressive strength of the grout at 14 days when compared to the results for grout made with distilled water.

2.2 GROUTING

2.2.1 Cement Grout:

Cement grout shall be a mixture of one part cement, two parts sand proportioned by volume admixtures for pressure grouting and sufficient water to form a workable mix.

2.2.2 Epoxy Grout for Crack Repair and Dowel Anchorage:

- a. Except for applications involving pressure grouting or crack injection, epoxy shall be a high modulus, moisture insensitive, two component, 100 percent solids, thermosetting modified polyamide epoxy compound. The material shall conform to ASTM C881 Type I, Grade 3 which is capable of not sagging in horizontal or overhead anchoring applications.
- b. Epoxy for applications involving pressure grouting or crack injection, shall be a high modulus, moisture insensitive, two component, injection grade, 100 percent solids blend of epoxy resin compounds. The material shall conform to ASTM C881 Type I, Grade 1 which is capable of achieving complete penetration of hairline and larger cracks.

2.2.3 Polymer Concrete for Resurfacing and Patching:

Polymer concrete shall consist of a liquid binder and dry aggregate mixed together to make a flowable mortar. The liquid binder shall be a chemical and oil resistant, stress relieved, low modulus, moisture insensitive, two component epoxy resin compound. The binder material shall conform to ASTM C881 Type 3, Grade 1 with a consistency similar to light weight oil for proper mixing with the aggregate. The aggregate shall be oven dry, kept in sealed packages until the time of mixing and be of size and consistency compatible with recommendations of the manufacturer of the liquid binder for the intended application.

2.2.5 Adhesive Resin for Dowel Anchorage:

ICC approved, structural epoxy; prepackaged in cartridges for manually or pneumatically operated caulk guns and automatically mixed at nozzle. Subject to compliance with the current ICC evaluation report.

2.3 PRESSURE GROUTING EQUIPMENT

Pressure grouting equipment shall include a mixer and holdover agitator tanks designed to place grout at pressures up to 50 psi (0.345 MPa). Gauges indicating grouting pressure shall be provided and the mixer shall be equipped with a meter capable of indicating to within 1/10 cubic foot (0.003 m³) the volume of grout placed.

PART 3 EXECUTION

3.1 GENERAL

Bonding compounds for use with grout is specified in [Division 03 Section "Concrete"] [Division 03 Section Cast-in-Place Concrete]. Primer, if required for polymer concrete, is to be provided and installed per the manufacturer's recommendations.

3.2 CEMENT GROUT

3.2.1 Cement grout is to be used for filling nonbearing portions of equipment pads and pressure grouting.

3.2.2 Except for the specialized requirements for pressure grouting, grout is to be mixed and placed in the same manner as cast-in-place concrete. Grout is to be mixed for at least one minute and diluted grout to agitate until placed.

3.3 NON SHRINK GROUT

3.3.1 Non-shrink, non metallic aggregate grout is to be used under equipment, bearing plates and column base plates. Non-shrinkable, metallic aggregate grout is to be used under rotating equipment where high strength and fatigue are of concern, to grout anchor bolts and to grout reinforcing steel. Grout is to be placed and cured in accordance with the manufacturer's recommendations.

3.3.2 Holes required for grouting shall be blown clean with compressed air and are to be free of dust or standing water. Horizontal holes for grouting are to be drilled at a slight downward angle and with the inserted dowel or bolt bent to match.

3.4 EPOXY GROUT

3.4.1 Epoxy grout shall be used for repairing cracks by pressure grouting or gravity, repairing structural concrete and may be used for setting dowels or bolts in holes. Concrete is to be primed in accordance with the grout manufacturer's recommendations.

3.4.2 The use of epoxy grout must comply with the following restrictions:

- a. Limited to areas where exposure, on an intermittent or continuous basis, to acid, chlorine gas or to machine or diesel oils, is extremely unlikely.

- b. Limited to applications where exposure to fire or to concrete temperatures above the product heat deflection temperature or 120 deg F (40 deg C)(whichever is less) is extremely unlikely. Overhead applications are not allowed.
- c. Holes for the anchors shall be drilled (not cored), shall be blown clean with compressed air and shall be free of dust or standing water.
- d. The anchor type, size and embedment depth shall be as shown on the drawings and the anchor must be installed in accordance with the manufacturer's recommendations.
- e. The anchor must not be loaded until after the full curing period has elapsed.

3.5 PRESSURED GROUTING

Prior to grouting, cracks and holes to be grouted shall be washed clean. Washing is not required for grouting soil voids. Once started, grouting shall be continuous until completed. In case of a mechanical failure or other stoppage of the work, the grout equipment shall be washed out sufficiently to ensure that fresh only grout is pumped when the work is restarted.

3.6 FIELD OF QUALITY CONTROL

3.6.1 The Testing Laboratory will:

- a. Special Inspect installation of anchors in accordance with applicable ICC Evaluation Report, where special inspection is indicated on Contract Documents or where Subcontractor's design engineer has used ICC anchor capacities that require Special Inspection.
- b. Develop and utilize an effective method of field marking anchor and dowel test locations and results.

3.6.2 Testing of grout mixes for conformance to manufacturer's specified strength: Testing laboratory shall take four test samples of each day's grout mix and test grout mix samples at 7 and 28 days. Test reports shall be submitted to the Architect/Engineer for evaluation and approval.

3.6.3 Test 25 percent of reinforcing steel dowels installed with adhesive resin on a given day in tension using pullout procedure. Test to 80% of specified yield strength of the dowel or 150% of the ICC rated static capacity whichever is the lesser with special inspection. Dowels specifically noted on the drawings as "No test required" do not require tension testing.

3.6.4 If the failure rate of dowels exceeds 10 percent, testing will be increased to 100 percent of that day's installation of similar anchors or dowels. Testing will be reduced to 25 percent of that day's installation when the failure rate is reduced

to 10 percent or less. Failed dowels will be replaced at no additional cost to the Owner. Subcontractor will reimburse Owner for the cost of additional testing.

END OF SECTION

SECTION 04 22 00

CONCRETE UNIT MASONRY

PART 1 GENERAL

1.1 SCOPE OF WORK

This section shall include all management, labor, materials, tools, equipment and services required to furnish and install concrete masonry units as specified herein and shown in Drawings required to perform all works in accordance to the General Conditions of the Contract Documents.

1.2 REFERENCES

Comply with quality assurance requirements under General Conditions of the Contract Documents and Manufacturer's instructions. Reference the following standards as Applicable:

1.2.1 American Concrete Institute (ACI)/American Society of Civil Engineers (ASCE)/The Masonry Society (TMS)

- A. ACI 117 – Standard Specifications for Tolerance for Concrete Construction and Materials.
- B. ACI 530.1/ASCE 6/TMS 315 - Specification for Masonry Structures.

1.2.2 American Concrete Institute (ACI)

- A. ACI 315 – Details and Detailing of Concrete Reinforcement.

1.2.3 American Society for Testing and Materials (ASTM)

- A. ASTM C 90– Specification for Load bearing Concrete Masonry Units.
- B. ASTM C 140 – Test Methods for Sampling and Testing Concrete Masonry Units and Related Units.

1.3 SUBMITTALS

1.3.1 General: All submittals for approval as indicated herein shall be in accordance with the provisions under General Conditions of the Contract Documents.

1.3.2 Product Data: For each type of concrete masonry unit and accessory including certifications that each complies with specified requirements.

1.3.3 Shop Drawings:

- A. For concrete masonry units, showing sizes, profiles, coursing, bond pattern, special shape locations, joint locations and embedded items.
- B. For cast stone trim in the form of cutting and setting drawings, showing sizes, profiles and locations of each stone trim unit required.
- C. For joint reinforcement and steel reinforcing. Detail fabrication, bending and placement of unit masonry reinforcing bars. Comply with ACI 315 showing reinforcing bar schedules, stirrup spacing, and diagrams of bent bars and arrangement of masonry reinforcing.
- D. Shop Drawings and/or manufacturer's catalog cuts of dovetail slots and other devices, if any, required for anchoring masonry to steel or other materials, including instructions for their proper use.

1.3.4 Samples:

Samples for approval for each different type and shape of exposed masonry unit required, showing full range of exposed color, texture and dimensions to be expected in the finished Work. When required by 2.01 B.6, prefaced or ground face, submit concrete masonry unit samples for color selection or verification. Two sample sections of cast stone sills and coping, if any, showing color and texture of finish. Samples of accessories embedded in masonry.

1.3.5 Quality Control Reports:

Submit copies of reports verifying compressive strength requirements of completed masonry, if required by the Engineer, within 7 calendar days of the date of each completed test.

1.4 QUALITY ASSURANCE

1.4.1 Comply with quality assurance requirements under General Conditions of the Contract Documents and Manufacturer's instructions.

1.4.2 Manufacturer Qualification shall be at least five (5) years of production experience, whose published literature clearly indicates general compliance of products with requirements of this section.

1.4.3 Single Source Responsibility

Obtain exposed masonry units of uniform texture and color from a single manufacturer for each type of product required.

1.4.4 Mock-ups

Where shown on the Contract Drawings, before masonry Work commences, construct a panel approximately 6 foot long by 4 foot high of each type of exposed concrete masonry unit, as directed by the Engineer, for approval. Use mortar of type and color to be used in the Work.

- A. Protect mock-ups from the elements with a weather-resistant membrane.
- B. Retain mock-ups during construction as standards for judging completed masonry Work. When directed by the Engineer, demolish mock-ups and remove them from Authority property.
- C. Prepare a list of materials used to construct mock-ups, for information only, for Engineers. Include manufacturer and product names, generic materials, suppliers, colors, identifying lot or batch numbers and design mixes.
- D. Where masonry is shown on the Contract Drawings to match existing, construct mock-up panels adjacent to and parallel to existing surfaces to be matched.

1.5 DELIVERY, STORAGE AND HANDLING

1.5.1 Comply with product delivery requirements under General Conditions of the Contract Documents and Manufacturer's instructions.

1.5.2 All materials shall be delivered, stored and handled so as to prevent the inclusion of foreign materials and damage of materials by water exposure and breakage. In stock piling concrete hollow blocks, measures shall be adopted to prevent the hollow blocks from resting directly on soil surface. These measures may include provision of pallets or beds of sand about 2" thick. Packaged materials shall be delivered and stored in original packages until ready for use. Packages or materials showing evidence of water exposure or other form of damage shall be rejected. All materials shall be of the respective qualities specified herein and packaged materials shall carry the manufacturer's labels thereon to permit identification.

1.6 WARRANTY

Special written warranty for each material specified herein shall be submitted by Manufacturer/Contractor without reducing or otherwise limiting any other rights to correction which the Owner may have under the Contract Documents. Failures are defined to include faulty workmanship or faulty materials.

1.7 PROJECT CONDITIONS

Comply with field examination requirements under General Conditions of the Contract Documents and Manufacturer's instructions.

PART 2 PRODUCTS

- 2.1 Specifications for the following materials are stated under section REINFORCED CONCRETE, and shall apply to this Masonry and Cement Work section as if written out in full.
- 2.2 Aggregates of different kinds and sizes shall be placed in different stock piles and positive means taken to prevent inclusion of foreign matter.
- 2.3 All cementitious materials must be kept dry until ready to be used; must be kept off the ground under cover, and away from sweating walls and other damp surfaces.
- 2.4 Cementitious materials that have hardened or partially set prior to actual use shall be removed from the site.
- 2.5 **Unit Masonry** - Concrete hollow block units shall be steam cured-weigh-batched units made. Concrete hollow block units shall be true to size, without cracks, chips, spawns, splits or other defects, which impair their strength or durability. They shall have three holes. All nonbearing type concrete blocks shall have a unit weight not to exceed 60 pcf, for load bearing type concrete blocks, a minimum compressive strength of 7.58 MPA (1,100 psi) shall be developed.

2.6 Steel Reinforcement

The minimum steel reinforcement for concrete hollow block walls shall conform to the schedule as given hereunder or as indicated in the construction notes.

	Minimum Vertical Reinforcement	Horizontal Reinforcement
4" CHB	10mm @ 0.4m	10mm @ 400mm
6" CHB	12mm @ 0.4m	10mm @ 400mm

All cores where vertical or horizontal reinforcements are placed shall be filled with mortar and shall thoroughly be worked inside the core to fill up voids.

2.7 Tie Wires : Ga. #16 G.I

2.8 Concrete Lintels

Lintels for openings shall be the height and thickness of existing hollow blocks or as detailed in the drawings. The minimum reinforcement shall be that shown in the drawings.

2.9 Mortars

Mortar mix shall be 1 part Portland Cement and 3parts white sand. All materials for mortar shall be measured by volume. Sand and cement shall be mixed dry and then water added to bring to proper consistency for use. No mortar that has stood for more than 3/4 of an hour shall be used. Retempering of mortar shall not be permitted. Discard mortar which has begun to stiffen.

PART 3 EXECUTION

3.1 Masonry Units

- 3.1.1** Lay all units plumb, true to line, level and accurately spaced.
- 3.1.2** Set in place anchors, wall plugs and accessories to masonry as erection progresses.
- 3.1.3** Bed solidly each course on Portland cement mortar with vertical joints breaking halfway over the course below.
- 3.1.4** Remove all loose mortar and thoroughly wet exposed joints not less than one hour before laying new work.

3.2 Plastering

- 3.2.1** All works shall be plumb, true and accurately done. Use screeds at convenient intervals to assure even and flat finish.
- 3.2.2** Scratch coat shall be applied evenly floated to true plumb and correct planes.
- 3.2.3** Not less than 24 hours after the application of scratch coat, the second of finish coat consisting of 1 part Portland cement and 2 parts sand shall be floated, red and finished to a combined finish total of approximately 3/4" for both 2 coats.
- 3.2.4** All exterior plastering works shall be done with a waterproofing ingredient, mixed with scratch and finish coats in strict accordance with the directions of the manufacturer of the waterproofing compound.
- 3.2.5** Each preceding coat shall be wetted before applying the next coat.
- 3.2.6** Plaster works shall not be started until all trades have completed their work. If this is not possible, the plasterer shall repair the broken and defective plaster and shall be done so that the finished surface presents an unbroken appearance.

END OF SECTION

SECTION 04 43 00

STONE MASONRY

PART 1 GENERAL

1.1 SCOPE OF WORK

This section shall include all management, labor, engineering, courier, printing, reproduction, materials, tools, equipment and services required to manufacture, assemble, deliver (including all import and export documents), and install all items

necessary for the proper execution and completion of said items of work, as indicated in the General and Special Conditions of the Contract documents, the Drawings, as specified herein, and /or as required by job conditions to provide the complete installation for steel doors and frames.

1.2 REFERENCES

Comply with quality assurance requirements under General Conditions of the Contract Documents. The following standards form part of these specifications to the extent referenced:

1.2.1 ASTM: American Society for Testing and Materials.

- a. C615 Standard Specification for Granite Dimension Stone.
- b. C97 Standard Test Methods for Absorption and Bulk Specific Gravity of dimension Stone.
- c. C99 Standard Test Method for Modules of Rupture of Dimension Stone.
- d. C170 Standard Test Method for Compressive Strength of Dimension Stone.
- e. C880 Standard Test Method for Flexural Strength of Dimension Stone.

1.2.2 Marble Institute of America (MIA): Membership, Products, and Services Directory.

- a. Dimension Stone Design Manual
- b. Dimension Stones of the World - Volumes I and II (includes color plates, ASTM test data and other technical information).

1.2.3 National Building Granite Quarries Association (NBGCQA) - Specifications for Architectural Granite.

1.3 SUBMITTALS

1.3.1 General: All submittals for approval as indicated herein shall be in accordance to the provisions under General Conditions of the Contract Documents.

1.3.2 Submit sample materials and swatches requirements for the stone finishes.

1.3.3 All samples submitted shall be of the production type and shall represent in all aspects the minimum quality of work to be furnished by the manufacturer, No work represented by the samples shall be started until the samples are approved and downgrading of quality from what was demonstrated by the samples may be cause for rejection of the work.

1.3.4 Submit certificates for compliance to standards applicable to material quality as specified herein.

Note: All Sample Material shall be submitted prior to purchasing and installing of materials for review and approval of the Architect.

1.4 QUALITY ASSURANCE

1.4.1 Comply with quality assurance requirements under General Conditions of the Contract Documents and Manufacturer's instructions.

1.4.2 Size of product: The inspector shall verify the physical size of natural stone material and thickness as specified.

1.5 DELIVERY, STORAGE AND HANDLING

1.5.1 Carefully pack and load finished natural stone for shipment using reasonable and customary precautions against damage in transit. Do not use material which may cause staining or discoloration for blocking or packing.

1.5.2 Store natural stone on timber or platforms at least 2" above the ground, and take care to prevent staining during storage. If storage is required for a prolonged period, place polyethylene or other suitable plastic film between wood and finished surfaces of completely dry stone. Keep finished natural stone countertops covered during storage.

1.6 WARRANTY

Special written warranty for each material specified herein shall be submitted by Manufacturer/Contractor without reducing or otherwise limiting any other rights to correction which the Owner may have under the Contract Documents. Failures are defined to include faulty workmanship or faulty materials.

PART 2 PRODUCTS

2.1 Acceptable Manufacturer shall have at least 10 years reliable and reputable manufacturing experience.

2.2 Floor Terminations

2.2.1 (FF-13) Natural Granite Stone Nosing 2: Interior Floor Termination Shall be 18-20mm thick x 50mm/100mm premium high quality natural granite stone in polished finish with medium to heavy resistance to abrasion, final color and pattern as per Architect's approved sample.

2.2.2 (FF-14) Natural Granite Stone Nosing 3: Interior Floor Termination and Toilet Entry Floor Nosing

Shall be 18-20mm thick x 50mm/150mm premium high quality natural granite stone in polished finish with medium to heavy resistance to abrasion, final color and pattern as per Architect's approved sample.

PART 3 EXECUTION

3.1 Manufacturer's Instruction

Comply with manufacturer's product technical data, installation procedures and standards as per project.

3.2 INSTALLATION

3.2.1 Provide competent stone setters. Set stone in accordance with approved shop drawings.

- a. Install backer material and primer where required. Follow the sealant manufacturer's instructions.
- b. Tool sealants ensure maximum adhesion to the contact surfaces.

3.3 CLEANING

3.3.1 Clean the natural stone, removing dirt, excess mortar, weld splatter, stains, and other site incident defacements.

3.3.2 Use stiff bristle fiber brushes. Do not use wire brushes or acid-type cleaning agents and other solutions, which may cause discoloration.

3.4 PROTECTION

3.4.1 Do not use lumber that may stain or deface the natural stone. If required, use only galvanized or non-rusting nails.

3.4.2 Protect natural stone from damage during the remainder of the construction period. Use suitable strong, impervious film or fabric securely held in place.

END OF SECTION

SECTION 05 52 00

METAL RAILING

PART 1 GENERAL

1.1 SECTION INCLUDES

The WORK of this section shall consist of furnishing and erecting steel hand railings on main staircase or at other locations as shown on the DRAWINGS, in accordance with the designs, dimensions instructions by ENGINEER, and these SPECIFICATIONS.

1.2 REFERENCES

1.2.1 The following is a list of standards which may be referenced in this section:

- a. American Institute of Steel Construction, Inc. (AISC).
- b. American Welding Society (AWS):
 - AWS D1.1/D1.1M, Structural Welding Code – Steel.
- c. ASTM International (ASTM):
- d. ASTM A53/A53M, Standard Specification for Pipe, Steel, Black and Hot-Dipped, Zinc-Coated, Welded and Seamless.
- e. ASTM A501, Standard Specification for Hot-Formed Welded and Seamless Carbon Steel Structural Tubing.

1.3 SUBMITTALS

1.3.1 Contractor shall submit detailed shop drawings based on field measurements to Architect for review prior to fabrication.

1.3.2 Paint and Stain Samples: If requested by Architect, prepare and submit paint samples. Remake samples until accepted.

1.3.4 Mock-up sample of railing for Architect's approval.

Note: All Shop Drawings and Sample Sections shall be submitted prior to purchasing and installing of materials for review and approval of the Architect.

PART 2 PRODUCTS

2.1 MATERIALS

2.1.1 Main Staircase Railing, Viewing Balcony Railing and Exterior Ramp

Shall be 42mm outside diameter, grade 304, stainless steel tubular handrail in hairline finish with 10mm thick x 40mm width, flat bar vertical balustrades, fully doweled to concrete zocalo at every 1950mm, coated with high performance two component solvent-based epoxy enamel paint finish; with 10mm x 40mm flat bar horizontal support balustrade, coated with high performance two component solvent-based epoxy enamel paint finish. Submit shop drawings, mock-up layout and sample for Architect's approval. Refer to Architectural drawings for layout and details.

2.1.3 **Miscellaneous:** The contractor shall fabricate plates or structural shapes as indicated in the drawings. Include welded anchors where detailed and furnish all items to be embedded in concrete or masonry.

2.2 FABRICATION

- 2.2.1** General: Field measures the headwall, wingwall, or location where the railing is to be installed, compare to the DRAWINGS, and review with Architect prior to fabrication.
- 2.2.2** Workmanship: Construct all items of sizes, shape, and materials as CONTRACTOR shall indicate and specify. Fabricate structural steel in accordance with AISC specifications and additional requirements specified hereafter; perform fabrication and assembly in the shop to the greatest extent possible; form materials well, with sharp angles or lines, free from bends, twists, or open joints; shear and punch clean, true lines and surfaces; thickness of metal and details of assembly and supports shall provide ample strength and rigidity.
- 2.2.3** Welding: CONTRACTOR shall perform welding in the shop with welders qualified under the AWS D1.1/D1.1M welding code for class of work employed; protect adjacent construction and materials against damage; neatly and symmetrically make all welds; fill or grind to a uniform, smooth shape; where required to present uniform appearance, fill space between welds and weld irregularities with suitable metal putty or compound made for this purpose.
- 2.2.4** Fastenings: CONTRACTOR shall provide concealed fastenings wherever possible; do not use screws or bolts where they can be avoided; where used, heads shall be countersunk, screwed up tight and threads nicked to prevent loosening; and make threaded connections tight so that threads shall be entirely concealed by fittings.
- 2.2.5** Paint: All products not specified by name shall be “best grade” or “first line” products available by the manufacturer. Railings which are not designated to be painted shall be galvanized or weathering steel according to the DRAWINGS. Shop clean primer on hollow metal WORK immediately before painting to remove grease and dirt film from surfaces.

PART 3 EXECUTION

3.1 GENERAL

- 3.1.1** CONTRACTOR shall erect structural steel in accordance with the specifications with modifications and additional requirements specified hereafter.
- 3.1.2** Erect all WORK true to lines and planes, with vertical lines plumb and horizontal lines level. Weld or bolt all permanent connections.

3.2 MISCELLANEOUS ANGLES, LINTELS AND EMBEDDED ITEMS

- 3.2.1** All welding procedures shall conform to AWS D1.1/D1.1M. All welds shall develop capacity of members being joined, unless specific length or extent is noted on the DRAWINGS.
- 3.2.2** Finish all cut ends neatly without irregular torch marks or sharp fins. Grind all cut surfaces to a smooth surface. Clean of all loose mill scale, rust, and foreign matter.
- 3.2.3** Any shop paint on surfaces adjacent to joints to be field welded shall be wire brushed to reduce the paint film to a minimum. Grind down burrs and sharp ridges at all exposed corners and surfaces of welds prior to field painting. After field welding, welded joints to be field primed.
- 3.2.4** The expansion bolts shall be installed per manufacturer's recommendations.

3.3 PAINTING

- 3.3.1** Inspection: Examine surfaces scheduled to receive paint and finishes for conditions that may adversely affect execution, permanence, or quality of WORK and which cannot be put into an acceptable condition through preparatory WORK as included under Paragraph Preparation.
- 3.3.2** Preparation:
 - a. Sanding: Sand metal surfaces between coats to ensure smoothness and adhesion of subsequent coats. Use extra fine sandpaper to avoid cutting the edges when sanding. Apply putty or spackling compound after surfaces are primed and primer is dry. Bring material flush with adjoining surfaces.
 - b. Surface Filling: Surfaces shall be perfectly dry, clean, and smooth before starting WORK. Fill cracks, holes, or scratches full and make smooth before finish is applied to surfaces.
 - c. Ferrous Metal: Remove foreign material from unprimed metal with wire brush and dust clean.
 - d. Shop Primed Metals: Touch up shop-primed metals with a primer similar to the existing.
 - e. Zinc-Coated Metal (Galvanized Surfaces): Wash with mineral spirits and prime as specified.
 - f. Protection: Furnish and lay drop cloths or mask off areas where finishing is being done to protect floors and other work from damage during the

execution of WORK. Where it becomes necessary to remove temporary coverings placed by others, replace same in proper manner.

- g. Damage to Work of Others: Be responsible for any damage done to the work of other trades, repairing same to the satisfaction of ENGINEER. Replace any materials damaged to such an extent that they cannot be restored to their original condition.

3.3.3 Workmanship:

- a. Existing Surfaces: If the surfaces are not in proper shape for painting, repair, rebuild, or refinish before proceeding with the WORK. CONTRACTOR is responsible for any poor WORK caused by improper surfaces. The application of the first coat does not relieve CONTRACTOR of the responsibility for failure of the base coat. Do not apply any coats on either damp or wet surfaces and in no case until the preceding coat is dry and hard.
- b. General: Apply materials evenly without runs or sagging of materials and according to the manufacturer's requirements. Sand WORK between coats.

3.4 TOUCH-UP PAINTING

CONTRACTOR shall, after erection of steel, apply touch-up paint to field bolt heads and nuts, field welds, and abrasions. When zinc coating has been scratched or removed from surfaces, three (3) coats of zinc rich paint shall be applied over the areas where the coating has been disturbed. Where excessive removal or damage the zinc coating has occurred, replacement of zinc coating by hot dipping in a zinc

bath may be necessary at the direction of ENGINEER.

END OF SECTION

SECTION 08 11 00

METAL DOORS, WINDOWS AND FRAMES

PART 1 GENERAL

1.1 SCOPE OF WORK

This section shall include all management, labor, engineering, courier, printing, reproduction, materials, tools, equipment and services required to manufacture, assemble, deliver (including all import and export documents), and install all items necessary for the proper execution and completion of said items of work, as indicated in the General and Special Conditions of the Contract documents, the Drawings, as

specified herein, and/or as required by job conditions to provide the complete installation for steel doors and frames.

1.2 REFERENCES

Comply with quality assurance requirements under General Conditions of the Contract Documents. The following standards form part of these specifications to the extent

Referenced:

- 1.2.1** ANSI A250.4-2001 – Test Procedure and Acceptance Criteria for Physical Endurance for Steel Doors, Frames and Hardware Reinforcing.
- 1.2.2** ANSI/NPFA 80-1999 – Standard for Fire Doors and Fire Windows
- 1.2.3** ANSI/NPFA 252-1999 – Standard Methods of Fire Tests of Door Assemblies
- 1.2.4** ANSI/UL 10B-2001 – Fire Test of Door Assemblies 9th edition
- 1.2.5** ANSI/UL 10C-2001 – Positive Pressure Fire test of Door Assemblies 1st edition
- 1.2.6** NAAMM Manufacturing of Hollow Metal Technical standards
- 1.2.7** USGBC – U.S. Green Building Council
- 1.2.8** LEED – Leadership in Energy and Environmental Design
- 1.2.9** GBCI – Green Building Certification Institute
- 1.2.10** EU Directives [WEEE & Ro HS]
- 1.2.11** PSA – Product Standards Agency
- 1.2.12** Steel Door Institute (SDI) – SDI-118 Basic Fire Door Requirements

1.3 TESTING AND PERFORMANCE

1.3.1 Physical Endurance for Steel Doors and Hardware Reinforcing

- a. Cycle Test Acceptance Criteria: ANSI A 250.4-2001 doors specified with Ga#16 and thicker face sheets shall be tested to 4,000,000 cycles. Door specified with Ga#18 thick face sheets shall be tested to 1,000,000 cycles level (A).
- b. Test Reports or Certificates of compliance shall include a description of the test specimen; procedures used in testing and indicate compliance with the contract document specified acceptance criteria.

1.3.2 Labeled Fire-Rated Doors and Frame Product

- a. Doors, frames, transom frames and sidelight assemblies provided for openings requiring fire protection, temperature rise and/or smoke and draft control shall be listed and/or classified and bear the label of a

testing agency having a factory inspection service. The product shall be tested in accordance with (ANSI/NFPA 252 or ANSI/UL-10C or UBC 7-2; Part 1) and constructed as listed or classified for labeling. Fire, temperature rise and/or smoke and draft control rating shall be determined and scheduled by the Architect.

- b. If any door or frame product specified by the Architect to be fire-rated cannot qualify for labeling because of design, over sizing, hardware or any other reason, the Architect shall be advised in the submittal documents. If hardware, glazing, or other options affect the fire-rating and are unknown at the time of submittal document preparation, the Architect shall be advised.
- c. Provide frames with an intumescent strip to prevent penetration of life treating hot smoke and hot gasses by expanding at 250°F and filling the gaps around the perimeter of the door once heated.
 - Intumescent strip is chemically inert, high stable, expandable graphite strip, unaffected by carbon dioxide and ozone. Self-adhesive acrylic adhesive is applied to one side which is insoluble in water and moisture resistant. Intumescent strips must be painted to match the finish color of Frame.
 - The frame is provided with recessed strips to protect, conceal the seal and reduce maintenance risk leading to effective and longer use.
- d. Use only hardware and accessories that are UL-listed for fire safety.

1.3.3 Environmental Safe

Provide doors and frames that is ecology friendly by restricting the use of certain hazardous substances pertaining to copper, mercury, cadmium, hexavalent and bromine type flame retarding materials.

1.4 SUBMITTALS

- 1.4.1** General: All submittals for approval as indicated herein shall be in accordance with the provisions under General Conditions of the Contract Documents.
- 1.4.2** Submit shop drawings, brochures and installation instructions. Clearly show details of each frame type, elevation of each door and window type, conditions and opening with various wall thickness and materials, typical and special details of door construction, methods of assembling sections, location, reinforcements, and installation requirements for hardware, size, shape and thickness of materials.
- 1.4.3** A sample of door showing edges, top and or bottom construction, insulation, hinge reinforcement and face stiffening shall be submitted.

- 1.4.4 A sample of typical frame showing welded corner joint, welded hinge reinforcement shall likewise be submitted.
- 1.4.5 All samples submitted shall be of the production type and shall represent in all aspects the minimum quality of work to be furnished by the manufacturer, No work represented by the samples shall be started until the samples are approved and any downgrading of quality from what was demonstrated by the samples may be cause for rejection of the work.
- 1.4.6 Submit test reports and certificates for compliance to standards applicable to material quality as specified herein.

Note: All Shop Drawings and Sample Sections shall be submitted prior to purchasing and installing of materials for review and approval of the Architect.

1.5 QUALITY ASSURANCE

- 1.5.1 Comply with quality assurance requirements under General Conditions of the Contract Documents and Manufacturer's instructions.
- 1.5.2 Quality Marketing: for fire rated doors, provide certifications indicating product data or attach a UL symbol to the door and frame.
- 1.5.3 Gauge of Components: The inspector shall verify that the steel thickness is specified.
- 1.5.4 Size of product: The inspector shall verify that the physical size of the doors and frames are as specified.

1.6 DELIVERY, STORAGE AND HANDLING

- 1.6.1 Comply with product delivery requirements under General Conditions of the Contract Documents and Manufacturer's instructions.
- 1.6.2 Correct site storage and protection are essential to proper performance of doors and frame products. The requirements for proper storage are the responsibility of the General Contract. However, it is important to recognize that these are not the responsibility of the hollow metal manufacturer. For this reason the requirements for storage and protection of hollow metal doors and frame products should be included in the Section of the specification where installation work is specified.
- 1.6.3 The Contractor is responsible for receiving hollow metal door and frame product shall remove wraps of covers upon delivery at the building site and shall ensure that any scratches or disfigurement caused by shipping or handling are promptly cleaned and touched up with Manufacturer's recommended material.
- 1.6.4 The Contractor is responsible for receiving door and frame product shall ensure that materials are properly stored on planks or in a dry location. Doors and frame products shall be stored in a vertical position, spaced by blocking. Materials

shall be covered to protect them from damage but in such a manner as to permit air Circulation.

1.7 WARRANTY

Special written warranty for each material specified herein shall be submitted by Manufacturer/Contractor without reducing or otherwise limiting any other rights to correction which the Owner may have under the Contract Documents. Failures are defined to include faulty workmanship or faulty materials.

PART 2 PRODUCTS

2.1 Acceptable Manufacturer

shall have at least 10 years reliable and reputable manufacturing experience.

2.2 Materials

2.2.1 Chromate – free Steel

- A. Electro galvanized steel sheet chromate-free coated with a special coating zinc coating layer applied on the base metal.
- B. Hot-Dip Galvanized Steel Sheet Chromate-free coated with a special coating film on hot dip galvanizing applied on the base metal.

2.3 Steel Door

Sizes and details as shown in drawings, dimension, fabrication and installation of Doors shall be based on the actual measurements and conditions of the site.

Location:

D-10a (Chairs & Tables Storage Rm 3)

2.3.1 Door Face Sheet: 1.3mm thick, gauge 18 minimum thickness and shall be manufactured from cold-rolled steel conforming to ASTM A 1011/A 1011M CS type B. Steel shall be free of scale, pitting, coil breaks or surface blemishes, buckles, waves or other defects.

2.3.2 Hollow Metal Panels: Shall be 45mm nominal thickness, shall be made of the same material specified on the door face sheet. Provide honeycomb core insulation.

2.3.3 Hollow Metal Frames: Shall be manufactured from cold rolled steel conforming to ASTM A1008/A 1008/M CS type B, or hot-rolled, pickled and oiled (HRPO) steel conforming to ASTM A 1011/A 1011M CS type B. Profiles shall be 1.6mm gauge 16 minimum thickness x 45mm x 140mm (framing size). Frame product shall be 1.7mm minimum thickness for single door openings

exceeding to 1,219mm in width and pairs with either door exceeding 1,219mm in Width.

2.3.4 Steel Door Finish: shall be in powder-coated finish

2.3.5 Hardware: Provide eUL listed steel door hardware complete with ball bearing hinges, lever type locksets, deadbolt, door closer, door stop and flush bolt (for double doors). See Section 087000 Hardware of the Technical Specification for further details.

2.4 Acoustical Steel Door (Breakout Room 1, 2, 3 & 4)

2.4.1 Door Face Sheet: 1.6mm thick, gauge 16 minimum thickness and shall be manufactured from cold-rolled steel conforming to ASTM A 1011/A 1011M CS type B. Steel shall be free of scale, pitting, coil breaks or surface blemishes, buckles, waves or other defects.

2.4.2 Hollow Metal Panels: Shall be 45mm nominal thickness, shall be made of same material specified on door face sheet. Filled in with sound absorbing material (fiberglass/rockwool on honeycomb insulation) with perimeter seal.

2.4.3 Hollow Metal Frames: Shall be manufactured from cold rolled steel conforming to ASTM A1008/A 1008/M CS type B, or hot-rolled, pickled and oiled (HRPO) steel conforming to ASTM A 1011/A 1011M CS type B.

Profiles shall be 1.6mm gauge 16 minimum thickness x 45mm x 140mm (framing size). Frame product shall be 1.7mm minimum thickness for single door openings exceeding to 1,219mm in width and pairs with either door exceeding 1,219mm in width.

2.4.4. Steel Door Finish: Shall be in stainless steel Grade 304, hairline finish (No. 4 finish); submit sample for Architect's approval.

2.4.5 Hardware: Provide UL listed steel door hardware, concealed door closer, standard rim cylinder, flush bolt (for double doors) jamb and head seal, threshold, automatic door bottom, meeting stile seal and accessories. Complete vertical pull handles (back to back). See Section 087000 Hardware of the Technical Specification for further details.

2.7 Steel Door with Bottom Louvers

Sizes and details as shown in drawings, dimension, fabrication and installation of Doors shall be based on the actual measurements and conditions of the site.

Location:

D-14b (Female Toilet 4)

2.7.1 Door Face sheet: 1.3mm thick, gauge 18 minimum thickness and shall be manufactured from cold-rolled steel conforming to ASTM A 1011/A 1011M CS type B. Steel shall be free of scale, pitting, coil breaks or surface blemishes, buckles, waves or other defects.

2.7.2 Hollow Metal Panels: Shall be 45mm nominal thickness, shall be made of the same material specified on the door face sheet. Provide honeycomb core insulation.

- 2.7.3 Steel Bottom Louvers:** Shall be 1.3mm thick Gauge 18 x 50mm x 75mm Z profile bottom louver blades (see drawings for design and details).
- 2.7.4 Hollow Metal Frames:** Shall be manufactured from cold rolled steel conforming to ASTM A1008/A 1008/M CS type B, or hot-rolled, pickled and oiled (HRPO) steel conforming to ASTM A 1011/A 1011M CS type B. Profiles shall be 1.6mm gauge 16 minimum thickness x 45mm x 140mm (framing size). Frame product shall be 1.7mm minimum thickness for single door openings exceeding to 1,219mm in width and pairs with either door exceeding 1,219mm in Width.
- 2.7.5 Steel Door Finish:** Shall be in powder-coated finish
- 2.7.6 Hardware:** Provide UL listed steel door hardware complete with ball bearing hinges, lever type locksets, door closer (for toilets only), door stop and flush bolt (for double doors only). See Section 087000 Hardware of the Technical Specification for further details.

PART 3 EXECUTION

3.1 Hollow Metal Doors Construction

- 3.1.1** Doors shall be the types, sizes and construction, in accordance with the contract documents, and shall meet the performance requirements, prior to shipment mark each door with an identification number as shown on approved submittal drawings.
- 3.1.2** Door face sheets shall be joined at their vertical edges by a continuous weld extending the full height of the door, with no seams on their faces or vertical edges.
- 3.1.3** Minimum nominal door thickness shall be 1-3/4 in (44mm). Doors shall be neat in appearance and free from warpage or buckle. Edge bends shall be true and straight and of minimum radius for the thickness of metal used.
- 3.1.4** Doors shall be stiffened by continuous vertically formed steel sections which, upon assembly, shall span the full thickness of the interior space between door faces. These stiffeners shall be 0.026in (0.6mm) minimum thickness, spaced so that the vertical interior webs shall be no more than 6 in. (152mm) apart and securely fastened to both face sheets by spot welds spaced a maximum of 5 in. (127mm) o.c. vertically. Spaces between stiffeners shall be filled with UL approved 12mm impregnated honeycomb core insulation.
- 3.1.5** The top and bottom edges shall be closed with a continuous steel channel, not less than 0.053 in. (1.3mm) thickness, welded to both face sheets.
- 3.1.6** Exterior doors, or where otherwise scheduled by the Architect, shall be closed flush at the top edge. Where required for the attachment for weather-stripping, a flush steel closure channel shall have exterior doors to permit the escape of entrapped Moisture.

3.1.7 Edge profiles shall be provided on both vertical edge of doors as follows, unless hardware dictates otherwise;

- a. Single acting doors – beveled 1/8in. (3.1mm) in 2 in. (50.8mm) profile.
- b. Double acting doors – rounded on 2-1/8 in. (54mm) radius.

3.1.8 Hardware Reinforcement and Preparations

- a. Doors shall be mortised, reinforced, drilled and tapped at the factory for template hardware only, in accordance with the approved hardware schedule and templates provided by the hardware supplier. Where surface mounted hardware, anchor hinges, thrust pivot reinforced hinges, or non-template hardware apply, doors shall be reinforced, with drilling and tapping done by others in the field.

- b. Minimum steel thickness for hardware reinforcements shall be as follows:

Full mortise hinges and pivots.....	0.0167 in. (4.2mm)
Lock fronts, strikes, concealed holders, or surface mounted closers.....	
.....	0.093 in. (2.3mm)
Internal reinforcements for other surface applied hardware.....	
.....	0.067 in. (1.7mm)

- c. In cases where electrically or electronically operated hardware is required, and indicated on the approved hardware schedule, conduit, hardware enclosures and/or junction boxes within the door shall be provided. Access plates, where required, shall be the same material and thickness as the door face sheets and shall be fastened with not less than four #3-32 machine screws at a spacing not to exceed 12 in. (305mm) in the center. Access plate screws shall be corrosion resistant. Fire doors that are normally held open shall be equipped with a device to automatically close the door in the event of fire.

3.1.9 Glazing Moldings and Stops

- a. Where specified or scheduled, doors shall be provided with steel holdings to secure glazing materials furnished and installed in the field by others, in accordance with glazing sizes and thickness shown in the contract documents.
- b. Fix glass molding shall be welded to the secure side.

- c. Removable glass stops shall be channel shaped, not less than 0.0032 in. (0.8mm) thickness, with tight fitting butt or mitered corners and secured with #6 minimum, corrosion resistant countersunk sheet metal screws.
- d. Metal surfaces to which glazing stops are applied, and the inside of the glazing stops shall be treated for maximum paint adhesion and painted with a rust inhibitive primer prior to installation in the door. Glazing stops fabricated from zinc-coated steel conforming to ASTM A 653/A 653M, A40 (ZF180) or G60 (Z180) for exterior openings need not be primed on the side.
- e. Fire rated doors shall be prepared for listed glazing as required in accordance with the door manufacturer's fire rating procedure.

3.1.10 Where specified in the contract documents, doors shall be provided with louvers.

- a. Louvers for non-wire rated doors shall be welded inverted V type, Y type, Z type, face pierced construction or louver inserts are permitted.
- b. Inverted V, Y and Z vanes shall be not less than 0.042 in. (1.0mm) thickness.
- c. Fire-rated doors shall be prepared for listed, automatic closing, fusible link and fire door louvers.
- d. Louvers for exterior doors shall be provided with insect and/or bird screens where shown on the contract documents.

3.2 Hollow Metal Frames Construction

3.2.1 Frame products shall have integral stops and be welded units of the sizes and types shown on approved submittal drawings. Frame products shall be constructed in accordance with the contract documents and meet the performance criteria. Knock down frames are not acceptable. Frame products shall be constructed in accordance with NAAMM HMMA 820 with regard to joint designs and welding techniques. Prior to shipment mark frame product with an identification number as shown on approved submittal drawings.

3.2.2 Finished work shall be neat in appearance, square and free of defects, warps and buckles. Pressed steel members shall be straight and of uniform profile throughout their lengths.

3.2.3 Jamb, header, mullion and sill profiles shall be in accordance with the frame schedule and as shown on the approved submittal drawings.

3.2.4 Corner joints shall have all contact edges closed tight with faces mitered and stops either butted or mitered.

a. Welding

Perimeter face joints (flush or indented) shall be continuously welded internally or externally. Flush face joints shall be smooth with seamless faces. Rabbets and soffits shall be continuously welded internally. The use of gussets or splice plates as a substitute for welding shall not be acceptable. Internal flush face joints shall be continuously welded and finished smooth with seamless faces.

Members at internal indented intersections shall be securely welded to concealed reinforcements and have hairline faces seams.

3.2.5 Minimum height of stops shall be 0.625 in. (15.8mm)

3.2.6 Cut-off, where specified shall be capped at heights as shown on the approved submittal drawings and jamb joints below cut-off stops shall be welded, filled and ground smooth so that there are no visible seams.

3.2.7 Each door opening shall be prepared for single stud, resilient door silencers, three (3) per strike jamb for single door openings, two (2) per head for pairs, except on gasket or weather stripped frame product. Silencers shall be supplied and installed by others.

3.2.8 When shipping limitations or site access dictate, or when advised by the contractor responsible for coordination or installation, frame products for large openings shall be fabricated in sections designated for assembly in the field by others. Alignment plates or angles shall be installed at each joint. Such components shall be the same material and thickness as the frame. Field joints shall be made according to approved submittal drawings and shall be field welded by others.

3.2.9 Hardware Reinforcements and Preparations

a. Frame products shall be mortised, reinforced, drilled and tapped at the factory for template hardware only, in accordance with the approved hardware schedule and templates provided by the hardware supplier. Where surface mounted hardware, anchor hinges, thrust pivots, pivot reinforced hinges, or non-templated hardware apply, frame products shall be reinforced with drilling and tapping done by others in the field.

b. Minimum steel thickness of hardware reinforcing shall be as follows:

Full mortise hinges and Pivots.....0.167 in. x 1.25 in. x 10 in. length (4.2mm x 31.7mm x 254mm)

Strikes.....0.0093 in. (2.3mm) or 0.053in. (1.3mm) unitized reinforcement with

extruded tapped holes that provide an equivalent number of threads as 0.093 in. (2.3mm)

Flush bolts, closers, hold open arms and other surface applied hardware.....0.093 in. (2.3mm)

3.2.10 In cases where electrically or electronically operated hardware is required, and indicated on the approved hardware schedule, conduit, hardware enclosure and/or junction boxes shall be provided. Access plates, where required shall be the same material and thickness as the frame product and shall be fastened with not less than four #8-32 machine screws of #6 sheet metal screw at a spacing not to exceed 12 in. (305mm) in the center.

3.2.11 Grout guards fabricated in frame product shall be provided with a temporary steel spreader welded to the feet of the jambs or mullions to serve as bracing during shipping and handling and which shall not be used for installation.

3.2.12 Removable Glazing Stops

- a. Where specified, frame product shall be provided with removable stops to secure glazing material or in-fill panels. Glazing materials shall be furnished and installed in the field by others, in accordance with glazing sizes and thickness shown in the contract documents.
- b. Removable steel channel glazing stops shall be butted at corners and secured to the frame section using #16 minimum, corrosion resistant countersunk sheet metal screws.
- c. The frame section underneath the glazing stops and the inside of the glazing stops shall be treated for maximum paint adhesion and painted with a rust inhibitive primer prior to installation in the opening. Glazing stops fabricated from zinc-coated steel conforming to ASTM A 653/A 653M, A40 (ZF120) for interior frames, A60 (ZF180) or G60 (Z180) for exterior openings need not be primed on the inside.

3.3 Hardware Locations

3.3.1 The location of hardware on doors and frame products shall be listed below. All dimensions, except the hinge locations are referenced from the floor.

- a. Hinges – use 125mm x 100mm, 3.4mm thick ball bearing butt hinge. Top 298mm from underside of frame rabbet at door opening to center line top of hinge. Bottom 330mm from floor to center line bottom of hinge. Intermediate centered between top and bottom hinges
- b. Locks and Latches – 1000mm to centerline of knob of lever shaft, 70mm backset minimum.

- c. Deadlocks – 1000mm to centerline of cylinder, 70mm backset minimum
- d. Exit Hardware – 1000mm to centerline of cross or as shown on hardware Template.
- e. Door Pulls – 1200mm to center grip
- f. Push/pull bars – 1200mm to centerline of bar
- g. Push Plates – 1200mm to centerline of plate
- h. Roller latches – 1150mm to centerline of latch

3.4 Finish

3.4.1 After fabrication, all tool marks and surface imperfections shall be filled and sanded as required to make face sheets, vertical edges and weld joints free from irregularities and dressed smooth.

3.4.2 After appropriate metal preparation, exposed surfaces of doors and frames shall receive a factory applied rust inhibitive primer.

3.4.3 Primer must be fully cured prior to shipment.

3.4.5 Final finish shall be coated with semi-gloss polyurethane paint finish; submit color swatches and samples for Architect's approval.

3.5 Manufacturer's Instruction

Comply with manufacturer's product technical data, installation procedures and standards as per project.

3.6 Field Examination

Manufacturer and Installer shall conduct actual measurement to verify or supplement dimensions provided and shall be accountable for the accurate fit of work required and shall verify site conditions to be acceptable for product installation in accordance with manufacturer's instruction.

3.7 Site Storage and Protection of Metals

Note: Correct site storage and protection are essential to proper performance of doors and frame products. The requirements for proper storage are the responsibility of the General Contractor. However it is important to recognize that these are not the responsibility of the hollow metal manufacturer. For this reason the requirements for storage and protection of hollow metal doors and frame products should be included in the section of the specification where installation work is specified.

3.7.1 The contractor responsible for receiving hollow metal door and frame products shall remove wraps or covers upon delivery at the building site and shall ensure

that any scratches or disfigurement caused by shipping or handling are promptly cleaned and touched up with a rust inhibitive “Direct to Metal” (DTM) primer.

- 3.7.2** The contractor responsible for receiving hollow metal door and frame product shall ensure that materials are properly stored on planks or dunnage in a dry location. Doors and frame products shall be stored in a vertical position, spaced by blocking. Materials shall be covered to protect them from damage but in such a manner as to permit air circulation.

3.8 Installation

Note: Correct installation is essential to the proper performance of doors and frame products.

The requirements for proper installation are given in the following Sections. However it is important to recognize that installation is not the responsibility of the hollow metal manufacturer. For this reason the requirements for installation should be included in the Section of the specifications where installation work is specified. It shall be the responsibility of the general contractor, using experienced personnel, to perform the work outlined below.

- 3.8.1** Prior to installation, the area of floor on which the frame product is to be installed, and within the path of the door swing, shall be checked for flatness.
- 3.8.2** Prior to installation, remove temporary spreaders. Doors and frame products shall be checked for correct size, swing fire rating and opening number.
- 3.8.3** During the setting of the frame, the product checked and corrected as necessary for opening width, opening height, squareness, alignment, twist and plumbness. Installation tolerance shall be maintained within the following limits.
- A. Opening Width – measured from rabbet to rabbet at top, middle and bottom of frame + 1/16 in. (1.5mm), - 1/32 in. (0.8mm)
 - B. Opening Height – measured vertically between the frame head rabbet and top of floor or bottom of frame minus jamb extensions at each jamb and across the head: + 1/16 in. (1.5mm), - 1/32 in. (0.8mm).
 - C. Squareness measure at rabbet on a line from jamb, perpendicular to frame head; not to exceed 1/16 in. (1.5mm).
 - D. Alignment measured at jambs on a horizontal line parallel to the plane of the face; not to exceed 1/16 in. (1.5mm).
 - E. Twist measured at the opposite face corners of jambs or parallel lines perpendicular to the plane of the door rabbet; not to exceed 1/16 in. (1.5mm).
 - F. Plumbness at the jambs on a perpendicular line from the head to the floor; not to exceed 1/16 in. (1.5mm). The above tolerance provides a reasonable guideline for proper installation of hollow metal frame products. However, it should be noted that the cumulative effect of the

installation tolerances at or near their maximum levels could result in sufficient misalignment to prevent the door from functioning properly. Installers should be careful not to create a tolerance build-up.

- 3.8.4** Grout guards and junction boxes are intended to protect hardware mortises and tapped holes from masonry grout of 4 in. (101mm) maximum slump consistency which is hand troweled in place. If a lighter consistency grout (greater than 4 in. (101mm) slump when tested in accordance with ASTM 143/C 143M) is to be used, special precautions must be taken in the field by the installer to protect the Aforementioned.
- 3.8.5** Frame products are not intended or designed to act as forms for grout or concrete. Grouting or hollow metal sections shall be done in “lifts” or precautions shall be otherwise taken by the contractor to ensure that frames are not deformed or damaged by the hydraulic forces that occur during this process.
- 3.8.6** Hollow metal surfaces shall be kept free from grout, tar and/or other bonding materials or sealers. Grout tar and/or bonding materials or sealers shall be promptly cleaned off frame product and doors.
- 3.8.7** The installer shall finish and touch-up marks caused by spreader removal.
- 3.8.8** Exposed hollow metal surfaces which have been scratched or otherwise marred during installation, cleaning and/or field welding, shall promptly be finished smooth, cleaned, treated for maximum paint adhesion and touched up with a rust inhibitive primer comparable to and compatible with the shop applied primer and finish paint.
- 3.8.9** Labeled fire door and frame products shall be installed in accordance with the terms of their listings, ANSI/NFPA 80, or the local Authority having jurisdiction.
- 3.8.10** Proper door edge clearances must be maintained except for special conditions otherwise noted. Where necessary, metal hinge shims, furnished by installer, are permitted to maintain clearances.
- 3.8.11** Hardware shall be applied in accordance with hardware manufacturer’s templates and instructions. Refer to 08700, Hardware.
- 3.8.12** Finish paint in accordance with Section 09900, Paints and Coating.
- 3.8.13** Install glazing materials. Refer to 08810, Glass.

3.9 Clearance

- 3.9.1** Edge clearance for swinging hollow metal doors shall be minimum of 1/32 in. (0.8mm) in order to provide for the functional operation of the assembly and shall not exceed the following:
 - A. Between doors and frame product at head and jambs – 3/16 in. (4.7mm)
 - B. Between edges of pairs of doors – 3/16 in. (4.7mm)

3.9.2 Floor clearance for swinging hollow metal doors shall not exceed the following:

- A. At the bottom of the door where threshold is used – 3/8 in. (9.5mm) from bottom of door to the top of threshold.
- B. At the bottom of the door where no threshold is used – 3/4 in. (19.0mm) above floor.
- C. Between bottom of door and nominal surface of floor coverings at fire-rated openings, as provided in ANSI/NFPA 80-1/2 in. (12.7mm).

END OF SECTION

SECTION 08 70 00

HARDWARE

PART 1 GENERAL

1.1 SCOPE OF WORK

This section shall include all management, labor, engineering, courier, printing, reproduction, materials, tools, equipment and services required to manufacture, assemble, deliver (including all import and export documents), and install all items necessary for the proper execution and completion of said items of work, as indicated in the General and Special Conditions of the Contract Documents, the Drawings, as specified herein, and /or as required by job conditions to provide the complete installation of hardware.

1.2 REFERENCES

Comply with quality assurance requirements under General Conditions of the Contract Documents. The following standards form part of these specifications to the extent referenced:

1.2.1 American National Standards Institute/ Builders Hardware Manufacturers Association, ANSI/BHMA:

- A. A156.1-2000, Butts and Hinges.
- B. A156.2-1995, Bored and Preassembled Locks and Latches.
- C. A156.3-2001, Exit Devices.
- D. A156.4-2000, Door Controls – Closers.
- E. A156.5-2001, Auxiliary Locks and Associated Products.

- F. A156.6-2001, Architectural Door Trim.
- G. A156.8-2000, Door Controls – Overhead Stops and Holders.
- H. A156.12-1999, Interconnected Locks.
- I. A156.13-2002, Mortise Locks and Latches, Series 1000.
- J. A156.14-2002, Sliding Door Hardware.
- K. A156.16-2002, Auxiliary Hardware.
- L. A156.18-2000, Recommended Practices for Materials and Finishes.
- M. A156.21-2001, Thresholds.
- N. A156.22-2003, Door Gasketing and Edge Seal Systems.
- O. ASTM F883-09, Standard Performance Specification for Padlocks.
- P. Underwriters Laboratories, UL.

1.3 SUBMITTALS

1.3.1 General: All submittals for approval as indicated herein shall be in accordance to the provisions under General Conditions of the Contract Documents.

1.3.2 Hardware Schedule: Submit a detailed hardware schedule indicating the following:

- A. Door and frame types, sizes, door swings.
- B. Type, Style, function, size and finish of each hardware item.
- C. Mounting heights, fastenings and other pertinent information.
- D. Name and manufacturer of each item.
- E. Location of all hardware items cross-referenced to door numbers indicated on floor plans and in door and frame schedule.
- F. Explanation of all abbreviations, symbols and codes contained in schedule.

1.3.3 Product Data: Manufacturer’s data sheets on each product to be used, including:

- A. Manufacturer’s maintenance instructions.
- B. Complete parts lists.
- C. Manufacturer’s installation and operation instruction for all operable hardware.

D. Keying Schedule.

1.3.4 Submit test reports and certificates for compliance to standards applicable to material quality as specified herein.

1.3.5 Shop Drawings: Manufacturer's approved shop drawings are required detailing the application of each product specified.

1.3.6 Samples: For each finished product specified, provide sample materials representing actual product, parts, finishes and patterns prior procurement.

1.3.7 After completion of all construction work, certify on a form acceptable to the Owner, that all items of finish hardware have been adjusted and are working properly; and that all hardware on fire rated/labeled doors and special doors conforms to the requirements of Underwriters Laboratories and standards applicable.

1.4 QUALITY ASSURANCE

1.4.1 Comply with quality assurance requirements under General Conditions of the Contract Documents and manufacturer's instructions.

1.4.2 Provide certifications indicating product data or attaché UL symbol to the door and Frame.

1.4.3 Manufacturer Qualifications: All equipment specified in this section will be provided by a single manufacturer with a minimum of ten (10) years-experience manufacturing door hardware.

1.4.4 Installer Qualifications: All products listed in this section are to be installed by a single installer with a minimum of five (5) years demonstrated experience in installing products of the same type and scope as specified in accordance to manufacturer's standard requirements.

1.4.5 Mock-Up: Provide a mock-up for evaluation of surface preparation techniques and application workmanship.

A. Finish areas designated by the Architect.

B. Do not proceed with remaining work until workmanship, color and sheen are approved by the Architect.

C. Refinish mock-up area as required to produce acceptable work.

1.5 DELIVERY, STORAGE AND HANDLING

1.5.1 Comply with product delivery requirements under General Conditions of the Contract Documents and Manufacturer's instructions.

1.5.2 Deliver hardware required for shop application in ample time so as not to impede the progress of the work.

- 1.5.3 Deliver finished hardware with all items in individual packages, legibly marked and adequately labeled indicating the part of the work for which it is intended. Include, with each item of hardware the following:
 - A. Screws, bolts and fastenings necessary for installation.
 - B. Installation instructions.
 - C. Special tools required for installation.
- 1.5.4 Provide a locked storage room with adequate shelving and bin space to properly receive and stock hardware prior to installation as designated by the Architect.
- 1.5.5 Protect door trims, handles, push plates and pulls with adhesive release paper, of type that is easily removed without marring finish.
- 1.5.6 For security reasons, forward all keys by hand to the authorized individual only, as designed by the Owner.



1.6 WARRANTY

Special written warranty for each material specified herein shall be submitted by Manufacturer/ Contractor without reducing or otherwise limiting any other rights to correction which the Owner may have under the Contract Documents. Failures are defined to include faulty workmanship or faulty materials.

PART 2 PRODUCTS

2.1 Verify hardware with Manufacturer’s Standard material requirements and designation in Door Hardware Schedule as shown in Drawings. Notify the Architect should conflict arise.

2.2 Schedule of Hardware Specifications

SCHEDULE OF HARDWARE SPECIFICATIONS	
<p>A. Manual Flush Bolt for Steel Doors Shall be UL listed manual flush bolt made from brass faceplate with steel component. Bolt shall be set on inactive door of a pair with 25mm x 172mm face plate and 13mm standard threaded rod size in satin chrome finish (US26D) with 3 hour fire rating for metal doors complying to ANSI 156.16 for L14251.</p>	
<p>OPTION 1: Hager 282D x US26D (steel doors and fire rated doors)</p> <div style="text-align: center;">  </div>	<p>OPTION 2: Hafele 911.62.013</p> <div style="text-align: center;">  </div>

C. One-Way Deadbolt Lock (no locking from the inside)

Shall be UL listed deadbolt lock, made from high-strength steel alloy deadbolt lock with maximum security cylinder retracted by key outside and blank plate with exposed screws inside, complying to ANSI/BHMA A156.5-2001, Grade 1 Lock in satin chrome finish. Provide patented tough nickel silver key.

OPTION 1:

Schlage B661P 626



OPTION 2:

Hafele911.64.582, blank plate inside



D. Ball Bearing Hinge

Shall be four (4) pieces, UL listed five knuckle ball bearing hinge made from stainless steel material with stainless steel pin, complying with ANSI A5112 and ANSI A2112, in satin chrome finish (US26D).

OPTION 1:

Model: for Wood Doors – 89mm x 89mm hinge size

For Steel Doors – 114mm x 102mm hinge size

Hager BB1191



OPTION 2:

Model: for Wood Doors - 89mm x 89mm hinge size Hafele 926.12.903

For Steel Doors – 114mm x 102mm hinge size Hafele 926.13.203



G. Vertical Pull Handle for Convention Hall Entrance Vestibule Doors – Steel Door

Shall be 1.2mm thick, 50mm diameters x 2000mm lengths stainless steel, back to back, vertical pull handle complying with ISO9001 (Architectural Hardware) in satin chrome finish.

Referenced brands and models shall be as follows or approved equal:

1. Dorma
2. EPCO Architectural Hardware

H. Lever Type Lockset (wood and steel doors)

Grade 2, UL listed, exceeds ANSI/ BHMA certified A 156.2, entrance function high security cylindrical lock with thru-bolted mechanism, concealed mounting screws and independent heavy duty spring cages for lever support. Provide dummy trim for double doors and patented tough nickel silver key. Referenced brands and models shall be as follows or approved equal:

1. Schlage AL-Series Jupiter no. 626 or US 26B finish, with dummy trim (for double swing doors)
2. Sargent Assa Abloy – B Lever Design –B-Solid Cast, G Rose Design with dummy trim (for double swing doors)

OPTION 1:

Note: follow specification finishes regardless of the image



OPTION 2:

Note: follow specification finishes regardless of the image



M. Concealed Door Closer

Grade 1, UL listed, ANSI standard A156.4, high strength concealed closer made from combination of cast iron bodied closers “oversized” hardened steel pistons and forged steel arms, complete with closing and latching speed hold open points adjusted. Referenced brands and models shall be as follows or approved equal:

- 1.LCN 3130 Series
- 2.Hafele – Concealed Door Closer



N. Door Stop 1
 UL listed, meets ANSI/BHMA A156.16, casted aluminum in satin chrome finish with rubber tip door stop. Referenced brands and models shall be as follows or approved equal:

1. Ives WS 447 US26D
2. Hafele 937.12.904



U. Door Indicator Lock for Toilet Cubicles
 Shall be nylon coated red/green color indicator for toilet doors by “Jebsen International Trading Inc. – Bescube – N-004” or approved equal.



X. Threshold, Automatic Door Bottom, Jamb and Head Seals and Meeting Stile Seals for Acoustical Steel Door

1. Threshold

Shall be in compliance to BS EN ISO 140-3 or ASTM Procedure E90, suitable for internal and external applications for both opening in & out doors. Shall be low level unit that satisfies the requirements of disabled provisions for wheel chair traffic and extensively tested for sound attenuating smoke sealing and weather sealing application; complete with gasket and other accessories in mill finish aluminum. Reference manufacturer shall be “Pemko – 2002 Thresholds” or approved equal Submit product catalog and sample for Architect’s approval. Follow manufacturer’s standard installation procedure and recommendation.

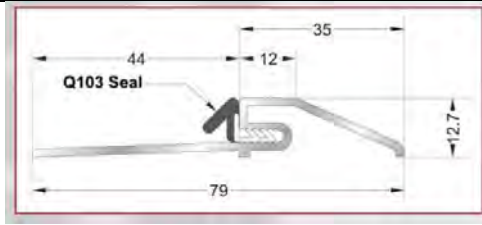

2. Automatic Door Bottom

Shall be in compliance to BS EN ISO 140-3 or ASTM Procedure E90; 14.3mm x 34.9mm automatic door bottom for 3-5mm floor gap in mill finish aluminum that provides excellent sound attenuating performance and provide smoke sealing and weather sealing performances, complete with screws and accessories. Reference manufacturer shall be “Pemko – 411 Fully Mortised” or approved equal Submit product catalog and sample for Architect’s approval. Follow manufacturer’s standard installation procedure and recommendation.

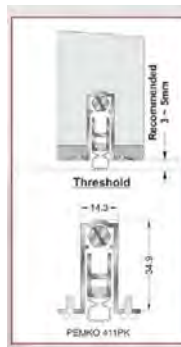

3. Jamb and Head Seals

Shall be in compliance to BS EN ISO-140-3 or ASTM Procedure E90, 6.3mm x 12.7mm x 11.5mm silicon seal in black color finish, compressing at 6.3mm and can be compressed sufficiently to seal openings of 3mm. Shall be self-extinguishing and non-toxic under fire condition and impervious to fungus and mildew. Reference manufacturer shall be “Pemko – S773 Siliconseal” or approved equal Submit product catalog and sample for Architect’s approval. Follow manufacturer’s standard installation procedure and recommendation.

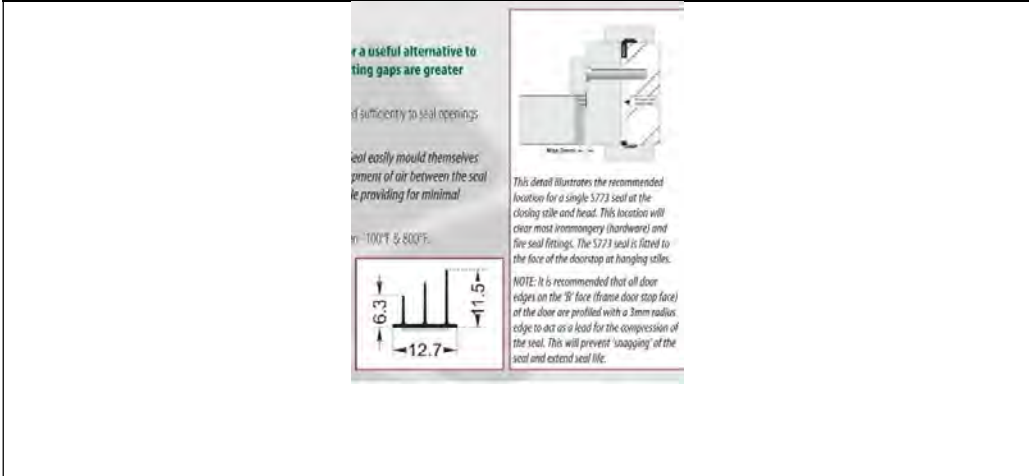

D. Meeting Stile Seals

Shall be in compliance to BS EN ISO-140-3 or ASTM Procedure E90, 6.4mm x 20.5mm stile seal in clear anodized aluminum finish recessed into the door that has been tested and suitable for use with sound attenuating door sets. Reference manufacturer shall be “Pemko – 29313 Meeting Stile Seals” or approved equal Submit product catalog and sample for Architect’s approval. Follow manufacturer’s standard installation procedure and recommendation.



PART 3 EXECUTION

3.1 Manufacturer’s Instruction

Comply with manufacturer’s product technical data, installation procedures and standards as per project requirement.

3.2 Field Examination

- 3.2.1** Manufacturer and Installer shall conduct actual measurement to verify or supplement dimensions provided and shall be accountable for the accurate fit of work and shall verify site conditions to be acceptable for product installation in accordance with manufacturer's instructions.
- 3.2.2** Do not begin installation until substrates have been properly prepared.
- 3.2.3** If substrate preparation is the responsibility of another installer, notify the Architect of unsatisfactory preparation before proceeding.

3.3 Preparation

- 3.3.1** Clean surfaces thoroughly prior to installation.
- 3.3.2** Prepare surfaces using the methods recommended by the manufacturer for achieving the best result for the substrate under the project conditions.

3.4 Installation

- 3.4.1** Provide metal door and frame manufacturers with complete instructions and templates for preparation of their work to receive hardware.
- 3.4.2** Install all items according to hardware manufacturer's instructions and recommendations. Mount at heights and centers according to manufacturer's instruction and standards.
- 3.4.3** Install hardware completely to ensure proper fit only finishing of door surfaces is complete.
- 3.4.4** Drill and countersink units which are prepared for anchorage of fasteners. Space fasteners and anchors to manufacturer's recommendations. Use only fasteners supplied by hardware manufacturers.
- 3.4.5** Protect doors and frames from damage due to installation of hardware.

3.5 Instruction

- 3.5.1** Instruct authorized Owner's personnel of the following:
 - A. Proper care, cleaning and general maintenance of hardware.
 - B. Operation of key control system. Make periodic checks during the warranty period to ensure functional efficiency of the system.

3.6 Protection

- 3.6.1** Protect installed products until completion of project.
- 3.6.2** Touch-up, repair or replace damaged products before Substantial Completion.

END OF SECTION

SECTION 08 83 00

MIRRORS

PART 1 GENERAL

1.1 RELATED DOCUMENTS

Drawings and general provisions of the Contract, including General and Supplementary Conditions and Division 01 Specifications, apply to this section.

1.2 SUBMITTALS

1.2.1 Product Data: For each type of product indicated.

Mirrors include description of materials and process used to produce each type of silvered flat glass mirror specified that indicates sources of glass, glass coating components, edge sealer and quality-control provisions.

1.2.2 Shop Drawings: Include mirror elevations, edge details, mirror hardware and attachments to other work.

1.2.3 Samples of the required materials.

1.3 INFORMATIONAL SUBMITTALS

1.3.1 Qualification Data: for required installer.

1.3.2 Product certificates: For each type of mirror and mirror mastic from the manufacturer.

1.3.3 Preconstruction Test Reports: From mirror manufacturer indicating that mirror was tested for compatibility and adhesion with mirror backing paint and substrates on which mirrors are installed.

1.3.4 Warranty: Sample of special warranty.

1.4 QUALITY ASSURANCE

1.4.1 Installer Qualifications: A qualified installer who employs glass installers for this project who are certified under National Glass Association's Certified Glass Installer Program.

1.4.2 Source Limitation for Mirror Accessories: Obtain mirror glazing accessories from a single source.

1.4.3 Preconstruction Mirror Compatibility Test: Submit mirror mastic products to mirror manufacturers for testing to determine compatibility of mastic with mirror backing paint and substrates on which mirrors are installed.

1.5 DELIVERY, STORAGE AND HANDLING

1.5.1 Protect mirrors according to mirror manufacturer's written instructions and as needed to prevent damage to mirrors from moisture, condensation, temperature changes, direct exposure to sun, or other uses.

1.5.2 Comply with mirror manufacturer's written instructions for shipping, storing and handling mirrors as needed to prevent deterioration of silvering, damage to edges and abrasion of glass surfaces and applied coatings.

1.6 PROJECT CONDITIONS

Environmental Limitations: Do not install mirrors until ambient temperature and humidity conditions are maintained at levels indicated for final occupancy.

1.7 WARRANTY

1.7.1 Special Warranty: Manufacturer's standard form which mirror manufacturer agrees to replace mirrors that deteriorate within specified warranty period. Deterioration of mirrors is defined as defects developed from normal use that are not attributed to mirror breakage or to maintaining and cleaning mirrors contrary to manufacturer's written instructions. Defects include discoloration, black spots and clouding of silver film.

PART 2 PRODUCTS

2.1 MATERIALS

2.1.1 Facial Mirror Male and Female Toilets

Shall be 6mm thick (for small mirrors) and 12mm thick (for full mirrors), frameless silver-coated float glass mirror with 2mm thick chamfered edges on both sides, glued to 12mm/18mm thick marine plywood backing and 25mm x 50mm TKD Tanguile framing using tile adhesive or mirror mastic with sponge tape on one side, facing wall. Provide screws with expansion shield and chrome-plated screw cap. Refer to Architectural Drawing for dimension, layout and design.

2.2 MISCELLANEOUS MATERIALS

2.2.1 Edge Sealer: Coating compatible with glass coating and approved by mirror manufacturer for use in protecting against silver deterioration and mirror glass edges.

2.2.2 Mirror Mastic: An adhesive setting compound, asbestos-free, produced specifically for setting mirrors and certified by both mirror manufacturer and mastic manufacturer as compatible with glass coating and substrate on which mirror will be installed.

2.2.3 Film backing for Safety Mirrors: Film backing and pressure-sensitive adhesive; both compatible with mirror backing paint as certified by mirror manufacturer.

2.3 MIRROR HARDWARE

- 2.3.1** Shall be 22mm x 29mm x 14.5mm thick glass support made from zinc alloy in stainless steel finish complete screw, gasket and plastic wall anchor for 6 and 12mm thick glass and mirror with backing. Submit sample for Architect's approval.

PART 3 EXECUTION

3.1 EXAMINATION

- 3.1.1** Examine substrates, over which mirrors are to be mounted, with installer present, for compliance with installation tolerances, substrate preparation and other conditions affecting performance of the work.
- 3.1.2** Verify compatibility with and stability of substrates, including compatibility of mirror mastic with existing finishes or primers.
- 3.1.3** Proceed with installation only after unsatisfactory conditions have been corrected and surfaces are dry.

3.2 PREPARATION

- 3.2.1** Comply with mastic manufacturer's written installation instructions for preparation of substrates, including coating substrates with mastic manufacturer's special bond coating where applicable.

3.3 INSTALLATION

- 3.3.1** General: Install mirrors to comply with mirror manufacturer's written instructions. Mount mirrors accurately in place in a manner that avoids distorting reflected images.
- 3.3.2** Provide a minimum air space of 1/8 inch (3 mm) between back of mirrors and mounting surface for air circulation between back mirrors and face of mounting surface.
- 3.3.3** Wall-Mounted Mirrors: Install mirrors with mastic and mirror hardware. Attach mirror hardware securely to mounting surfaces with mechanical fasteners installed with anchors or inserts as applicable. Install fasteners so heads do not impose point loads on the backs of mirrors.

3.4 CLEANING AND PROTECTION

- 3.4.1** Protect mirrors from breakage and contaminating substances resulting from construction operations.
- 3.4.2** Do not permit edges of mirrors to be exposed to standing water.
- 3.4.3** Maintain environmental conditions that will prevent mirrors from being exposed to moisture from condensation or other sources for continuous periods of time.

- 3.4.4** Wash exposed surface of mirrors not more than four days before the date scheduled for inspections that establish the date of Substantial Completion. Wash mirrors as recommended in writing by the mirror manufacturer.

END OF SECTION

SECTION 09 21 16

GYPSUM BOARD

PART 1 GENERAL

1.1 SCOPE OF WORK

This section shall include all management, labor, materials, tools, equipment and services required to furnish and install gypsum boards for walls as specified herein and shown in Drawings required to perform all works in accordance to the General Conditions of the Contract Documents.

1.2 REFERENCES

Comply with quality assurance requirements under General Conditions of the Contract Documents and Manufacturer's instructions. Referenced the following standards as applicable:

- 1.2.1** American Society of Testing and Materials (ASTM)
- A. ASTM C36 Standard Specification for Gypsum Wallboard
 - B. ASTM C475 Standard Specification for Joint Compound and Joint Tape for finishing Gypsum Board
 - C. ASTM C514 Standard Specification for Nails for the Application of Gypsum board
 - D. ASTM C840 Standard Specification for Application and Finishing of Gypsum board
 - E. ASTM C1395 Specification for Gypsum Ceiling Board
 - F. ASTM C1396 Standard Specification for Gypsum Board
 - G. ASTM E413 Classification for Rating Sound Insulation
 - H. ASTM E90 Standard Test Method for Laboratory Measurement of Airborne Sound Transmission Loss of Building Partitions and Elements

1.3 SUBMITTALS

- 1.3.1** General: All submittals for approval as indicated herein shall be in accordance to the provisions under General Conditions of the Contract Documents.
- 1.3.2** Product Data: Submit product information from manufacturers for each type of product specified to include brochures, catalogs, sample and certificates of tests reports, quality compliance and accreditation from foreign manufacturer for authenticity of local distributed materials.

1.4 QUALITY ASSURANCE

- 1.4.1** Comply with quality assurance requirements under General Conditions of the Contract Documents and Manufacturer's instructions.
- 1.4.2** Manufacturer Qualification shall be at least five (5) years of production experience, whose published literature clearly indicates general compliance of products with requirements of this section.
- 1.4.3** Single Source Responsibility
Obtain gypsum boards of uniform quality from a single manufacturer for each type product required.
- 1.4.4** Tests:
 - A. Sound Transmission Characteristics (STC): For gypsum board assemblies with STC Ratings, provide materials and construction identical to those tested in assembly indicated according to ASTM E90 and classified according to ASTM E413.

1.5 DELIVERY, STORAGE AND HANDLING

- 1.5.1** Comply with product delivery requirements under General Conditions of the Contract Documents and Manufacturer's instructions.
- 1.5.2** Deliver materials in manufacturer's original unopened packages clearly marked with identifying information. Protect materials as recommended by the manufacturer.
- 1.5.3** Store materials, keep dry, and protect against damage from weather, direct sunlight, surface contamination, corrosion, construction traffic, and other causes. Stack gypsum panels on level surface to prevent sagging.

1.6 WARRANTY

Special written warranty for each material specified herein shall be submitted by Manufacturer/ Contractor without reducing or otherwise limiting any other rights to correction which the Owner may have under the Contract Documents. Failures are defined to include faulty workmanship or faulty materials.

1.7 PROJECT CONDITIONS

- 1.7.1** Comply with field examination requirements under General Conditions of the Contract Documents and Manufacturer's instructions.
- 1.7.2** Environmental Conditions: Establish and maintain environmental conditions for application and finishing of gypsum board to comply with ASTM C840 and with gypsum board manufacturer's recommendations.
- 1.7.3** Minimum Room Temperatures: For attachment of gypsum board to framing, maintain not less than 40 degrees F. For finishing of gypsum board, maintain not less than 50 degrees F for 48 hours prior to application, and continuously thereafter until drying is complete.
- 1.7.4** Ventilation: Ventilate building spaces to remove water not required for drying joint treatment materials. Avoid drafts during dry, hot weather to prevent materials from drying too rapidly.

PART 2 PRODUCTS

2.1 Wallboards

- 2.1.1** Drywall partitions shall be 12mm thick x 1200mm x 2400mm, sag resistant regular gypsum board with ivory face paper, shall be coated with high performance low VOC, odorless, ultra-premium water-based acrylic coating that gives a cleanable matte finish to walls and ceilings with surface protector and anti-bacterial protection.
- 2.1.2** Adhesive for joint and fastener concealment shall be of the types recommended in writing by the wallboard manufacturer and as approved for the following uses:
 - A. Embedding compounds for first and second coats.
 - B. Finishing compound for final coat.
- 2.1.3** Backing board shall be of the grade and form required for the insulation.
- 2.1.4** Wall and partition metal assemblies shall be as manufactured. Assemblies shall be as follows:
 - A. Track, top and bottom shall be galvanized steel gauge 22 or 24 and 2.4 or 3.0m long.
 - B. Stud shall be galvanized steel, gauge 22 or 24 and 2.4 or 3.0m long.
- 2.1.5** Fasteners.
 - A. Bolts and nuts shall be recommended by the framing manufacturer, steel and zinc-coated.
 - B. Expansion shields shall be of the type and class applicable.
 - C. Powder-driven fasteners as per Architect's approval.
- 2.1.6** Screws for board attachment shall be shouldered flat-head design for use with special power-driven tools.
 - A. Wood Screws shall be not less than 15mm (1-1/8 inches) long.
 - B. Metal screws shall be not less than 25mm long with self-tapping threads and self-drilling points.
- 2.1.7** Toggle bolts shall be of the type and class best suited for the purpose.

PART 3 EXECUTION

3.1 General

- 3.1.1** Examination: Examine areas and substrates, with installer present, and including hollow-metal frames, anchors, and structural and non-structural framing, for compliance with other requirements and other unsatisfactory conditions have corrected.
- 3.1.2** Steel Framing Installation Standard: Install steel framing to comply with ASTM C754 and with ASTM C840 requirements that apply to framing installation.
- 3.1.3** Install supplementary framing, blocking and bracing at terminations in the gypsum board assemblies to support fixtures, equipment services, heavy trim, grab bars, toilet accessories, furnishings, and similar construction. Comply

with details indicated and with gypsum board manufacturer's written recommendations.

3.2 Installation for Walls

- 3.2.1** Walls: Furring channels shall be spaced 0.40m on centers. Furring shall be secured to masonry or concrete with hardened nails, toggle bolts, expansion shields, or other approved method at not more than 0.60m centers staggered in alternate flanges of channel with one fastener located within 150mm of each end. Furring shall be secured to structural framing as shown. Furring shall be set plumb or level and rigid using shims of galvanized steel wherever necessary to assure a finished wall surface in a true, even plane. Board abutting dissimilar wall or ceiling materials shall have edges finished with casing beads aligned to provide a finished joint.
- 3.2.2** Steel framing: Non- load bearing walls and partitions shall be framed with 64mm and 92mm steel studs and runners installed as indicated and as hereinafter specified. Studs shall be spaced not more than 0.60m on centers and end studs in adjoining walls shall be interconnected with screws spaced at not more than 0.60m centers.
- 3.2.3** Application: Wallboard shall be applied with the separate boards in moderate contact but not forced into place. At internal and external corners the cut edges of the boards shall be concealed by the overlapping covered edges of the abutting boards. The boards shall be so staggered that the corners of any board will not meet a common point except in vertical corners.
- A. Single-ply horizontal application: The long dimension of the panels shall be placed at right angles to the furring or framing members. End joints, where required, shall be made over furring or framing members.
- B. Single-ply vertical application: The long dimension of the panels shall be placed parallel to the furring or framing members. the panels shall be of the length required to reach from the ceiling line to the floor line in one continuous length. Joints shall be made over framing or furring members.
- 3.2.4** Control Joints: shall be formed of casing bead trim installed back-to-back over separate framing or furring members. A spacing of 3mm shall be maintained between opposite beads. Control joints shall be located as indicated.
- 3.2.5** Attachment: If the paper surface is broken in nailing or screwing, another nail or screw shall be driven approximately 50mm from the faulty nailing or screwing. Attachment of wallboard to steel furring and steel framing shall be screw fasteners only. Nailing or screw attachment shall proceed from central portion of wallboard toward end and edges.
- 3.2.6** Joint and fastener concealment: Areas to be treated shall be inspected by the contractor to ascertain that wallboard fits tightly against supporting framework, and these areas shall be heated to not less than 55 degrees F. for 24 hours prior to commencing treatment, during treatment, and until adhesive compounds have dried. Application shall be by machine or hand tool. A minimum drying time of 24 hours shall be allowed between adhesive coats. Additional drying time may be necessary in poorly ventilated areas.

- A. Embedding compound: Shall be applied to wall board joints and fastener heads in a thin uniform layer. Compound shall be spread not less than 75mm wide at joints, and reinforcing tape shall be centered on the joint and embedded in the compound. A thin layer of compound shall be spread over the tape. After this treatment has dried, a second coat of embedding compound shall be applied to wallboard joints and fastener heads. Compound shall be spread in a thin uniform coat and not less than 150mm wide at joints. Treated areas shall be sanded to eliminate ridges and high points.
- B. Finishing compound: After embedding compound has dried, a coat of finishing compound shall be applied to joints and fastener heads. Finishing compound applied at joints shall be feathered out to not less than 300mm (12 in) wide. After compound has dried, the treated areas shall be sanded as necessary to obtain uniformly smooth surfaces. Care shall be taken not to scuff the paper surface of the wallboard.

3.2.7 Corner Treatment

- A. Internal corners: Shall be treated in the manner specified here-in-before for joints, except that the reinforcing tape shall be folded lengthwise through the middle and fitted neatly into the corner.
- B. External corners: Shall have corner bead fitted neatly over the corner and secured with the same type fastener used for applying wallboard. The fastener shall be spaced approximately 150mm on centers and driven through the wallboard into the framing member. After the corner-piece has been secured in place, the corner shall be treated with joint compound and reinforcing tape in the manner here-in-before specified for joints. The joint compound shall be feathered out from 200mm to 250mm, on each side of corner.

3.4 Cleaning and Protection

- 3.4.1** Promptly remove any residual joint compound from adjacent surfaces not indicated to receive texture.
- 3.4.2** Provide final protection and maintain conditions, in a manner acceptable to Installer, that ensure gypsum board assemblies are without damage or deterioration at the time of construction complete.

END OF SECTION

SECTION 09 24 00

PLASTERING

PART 1 GENERAL

1.1 SCOPE OF WORK

This section shall include all management, labor, materials, tools, equipment and services required to furnish and install plastering as specified herein and shown in Drawings required to perform all works in accordance to the General Conditions of the Contract Documents. All masonry unit work or concrete work not specifically specified with a finish, exposed to view shall be cement plastered. Plastering work shall be coordinated properly with the work of other trades. The work of other trades shall be protected properly from damage during plastering operations. Floors and finished work shall be properly protected with a covering of polyethylene sheets or heavy kraft waterproof paper, with lapped and sealed joints. Scaffolding shall be amply strong, well braced, tied securely and inspected regularly. Overloading of scaffolding will not be permitted.

1.2 REFERENCES

Comply with quality assurance requirements under General Conditions of the Contract Documents and Manufacturer's instructions. Reference the following standards as applicable:

- 1.2.1** ASTM C 926-98a Standard Specification for Application of Portland Cement-Based Plaster
- 1.2.2** ASTM C 932-02 Standard Specifications for Surface-Applied Bonding Compounds for Exterior Plastering
- 1.2.3** ASTM C 1063-03 Standard Specification for Installation of Lathing and Furring to receive Interior and Exterior Portland Cement-based Plaster.

1.3 SUBMITTALS

All submittals for approval as indicated herein shall be in accordance to the provisions under General Conditions of the Contract Documents.

1.4 QUALITY ASSURANCE

Comply with quality assurance requirements under General Conditions of the Contract Documents and Manufacturer's instructions.

1.5 DELIVERY, STORAGE AND HANDLING

- 1.5.1** Comply with product delivery requirements under General Conditions of the Contract Documents and Manufacturer's instructions.
- 1.5.2** Manufactured materials shall be delivered in the original packages and containers bearing the name and brand of the manufacturer. Cement and lime

shall be stored off the ground under watertight cover, and away from sweating walls and damp surfaces, until ready for use. Damaged or deteriorated materials shall be removed from the premises.

1.6 WARRANTY

Special written warranty for each material specified herein shall be submitted by Manufacturer/Contractor without reducing or otherwise limiting any other rights to correction which the Owner may have under the Contract Documents. Failures are defined to include faulty workmanship or faulty materials.

1.7 PROJECT CONDITIONS

Comply with field examination requirements under General Conditions of the Contract Documents and Manufacturer's instructions.

PART 2 PRODUCTS

- 2.1** Portland Cement: Shall conform to PNS 07-1992, type 1.
- 2.2** Sand: Shall be clean natural sand or manufactured sand passing a 3mm screen and retained in a No. 100 mesh sieve.
- 2.3** Water: For mixing shall be potable.
- 2.4** Lime: Shall be hydrated lime with the requirement that the free (Unhydrated) calcium oxide (CaO) and magnesium oxide (MgO) in the hydrated product shall not exceed 8 percent by weight calculated on the "as received" basis.

PART 3 EXECUTION

3.1 Preparation

3.1.1 Mixing of plaster: Except where hand mixing of small patches is approved, mechanical mixers of an approved type shall be used for the mixing of plaster. Materials shall be accurately measured in a device that will maintain the specified proportions within a plus or minus tolerance not in excess of 5 percent by volume. Caked or lumped materials shall not be used. Mechanical mixers, mixing boxes, and tools shall be cleaned after mixing each batch and kept freely of plaster from previous mixes. Plaster shall be thoroughly mixed with the proper amount of water, until uniform in color and consistency. Re-tempering will not be permitted, and all plaster that has begun to stiffen shall be discarded.

3.1.2 Proportioning of plaster: Portland cement plaster shall be a two-coat application.

Each coat shall be proportioned as follows:

One (1) part Portland Cement

Three (3) parts Sand; and

One-fifth (1/5) part Lime Putty

- 3.1.3** Application of plaster: Base coats shall be applied with sufficient pressure and the plaster shall be sufficiently plastic to provide good bonds on masonry or concrete base. Plaster work shall be finished level, plumb, square and true, within a tolerance of 3mm in 3m, without eaves, cracks, blisters, pits, grazing, discoloration, projections or other imperfections. Plasterwork shall have no visible junction marks where one day's work adjoins another. Finished work shall be covered and protected in an approved manner to prevent damage.
- 3.1.4** Portland Cement Plaster: Shall be applied in two coats double-up method on masonry or concrete to a thickness of not less than 12mm. Base coats shall be applied with sufficient pressure and excessive evaporation during hot or drying weather conditions. Care shall be taken to prevent staining the finished plaster.
- 3.1.5** Patching and pointing: Upon completion of the building and when directed, all loose, cracked, damaged, or defective plastering shall be cut out and re-patch in a satisfactory and approved manner. All point-patching of plastered surfaces, and plaster work abutting or adjoining any other finish work, shall be done in a neat and workmanlike manner. Plaster droppings or splattering shall be removed from all surfaces. Exposed plastered surfaces shall be left in a clean unblemished condition ready to receive paint or other finish. Protective coverings shall be removed from floors, other surfaces, and all rubbish and debris shall be removed from the building.

END OF SECTION

SECTION 09 30 00

TILES

PART 1 GENERAL

1.1 SCOPE OF WORK

This section shall include all management, labor, materials, tools, equipment and services required to furnish and install tile works as specified herein and shown in Drawings required to perform all works in accordance to the General Conditions of the contract Documents. The work shall not be started until the roughing-in for plumbing and electrical work has been completed and tested. The work of all other trades in the area where tile work is to be done shall be protected from damage in a skillful manner and as directed.

1.2 REFERENCES

Comply with quality assurance requirements under General Conditions of the Contract Documents and Manufacturer's instructions. Reference the following standards as applicable:

- 1.2.1** American National Standards Specifications (ANSI), Standards for Tile Installation:

- A. ANSI 108
- B. ANSI 118
- C. ANSI 136.1
- D. ANSI A 137.1

1.2.2 American Society for the Testing of Materials (ASTM), ASTM C 270, Standard Specification of Mortar for Unit Masonry

1.3 SUBMITTALS

1.3.1 General: All submittals for approval as indicated herein shall be in accordance to the provisions under General Conditions of the Contract Documents.

1.3.2 Manufacturer's literature: Product data sheets, brochures, catalogs for all tile materials used for the work.

1.3.3 Certifications: Prior to delivery, submit certificates to the Architect attesting to compliance with the applicable Specifications herein.

1.3.4 Manufacturer's grout color charts. Sample of grout: Cured sample, 2 x 2 inches of selected colors.

1.3.5 Tile samples of the actual tile to be provided shall be submitted for approval before tile work has started. The finish work shall match the approved samples in sizes, color pattern, finish and texture.

1.4 QUALITY ASSURANCE

1.4.1 Comply with quality assurance requirements under General Conditions of the Contract Documents and Manufacturer's instructions.

1.4.2 Source Limitations: Obtain all tiles of same type and color or finish tile from one source or producer. Materials shall be of the same production run and of consistent quality in appearance and physical properties for each contiguous area.

1.4.3 Setting materials such as mortar, adhesive and grout components shall be of uniform quality from a single manufacturer as well as finish treatments for nosing, stone thresholds and metal strips.

1.5 MOCK – UPS

Build mock-ups to verify selection made under sample submittal and to demonstrate aesthetic effects. When completed and approved by the Architect, the mock-up shall be incorporated into the finished Work and become the Standard of quality for the remainder of the Project.

1.6 DELIVERY, STORAGE AND HANDLING

- 1.6.1** Comply with product delivery requirements under General Conditions of the Contract Documents and Manufacturer's instructions.
- 1.6.2** Manufactured materials shall be delivered in the original unbroken packages or containers that are labeled plainly with the manufacturer's name and brands. Containers for tiles shall be grade sealed.
- 1.6.3** Store all materials off ground to prevent contamination by mud, dust, or materials likely to cause staining or other defects. Cover material to protect from elements and neglect.

1.7 WARRANTY

Special written warranty for each material specified herein shall be submitted by Manufacturer/ Contractor without reducing or otherwise limiting any other rights to correction which the Owner may have under the Contract Documents. Failures are defined to include faulty workmanship or faulty materials.

1.8 PROJECT CONDITIONS

- 1.8.1** Comply with field examination requirements under General Conditions of the Contract Documents and Manufactures instructions.
- 1.8.2** Verify dimensions of concrete substrate by accurate field measurement. Confirm concrete has been in place for at least 28 days prior to commencing tile installation. Do not begin work until deficiencies in the substrate are corrected. Commencement of tile installation indicates Contractor's acceptance of substrate.
- 1.8.3** Do not install until construction in spaces is complete and ambient temperature and humidity conditions are maintained at the levels indicated in referenced standards and Manufacturer's instructions.

1.9 EXTRA MATERIALS

- 1.9.1** Comply with requirements under General Conditions of the Contract Documents and Manufacturer's instructions.
- 1.9.2** Furnish extra materials that match products installed and that are packaged with protective covering for storage with quantity of full size units for tile and trims units equal to two (2) percent of amount installed, for each type, composition, color, pattern and size indicated.

1.10 PERFORMANCE REQUIREMENTS

Materials are to be from an accredited company with accomplished projects similar to the quality of material as specified herein. The Contractor shall submit tile samples to the Architect for approval prior to any installation. Design including texture and pattern shall be kept minimal with neutral color assignment as per Architect's approved sample.

Submit material test reports and certificates acquired by Manufacturer from reputable testing and accreditation agency.

PART 2 PRODUCTS

- 2.1 Portland Cement** shall be gray color for mortar setting bed and scratch coat. This shall conform to the requirements of PNS 07-type 1.
- 2.2 Tile Grout** for grouting shall be high performance, waterproof, cement-based tile adhesive conforming to PNS 53 with early high-strength Characteristics. Color of grout shall match tile material as per Architect's approved sample.
- 2.3 Hydrated Lime** shall be the same quality as that used for masonry work.
- 2.4 Sand for Mortar** setting beds shall conform to the requirements of ASTM Specification C44.
- 2.5 Sand for Plaster** scratch coats and pointing mortar shall conform to the requirements of ASTM Specification C35.
- 2.6 Water** shall be clean and free from injurious amount of oil, acids, alkali, organic materials or other substances that may be deleterious to concrete or steel.
- 2.7 Floor and Pavement tiles**

2.7.4 FF-4 General Flooring: Polished Finish Homogeneous Porcelain Tiles

Shall be 10mm thick x 600mm x 600mm double polished finish anti-stain, homogeneous porcelain tiles with heavy resistance to abrasion Class AAA, 7.5 kgs. Final color and pattern as per Architect's approved sample. Provide 2-3 mm gap in between tile joints during installation. Tile color and design shall be approved first before installation.

2.7.7 FF-8 Main Stairs Flooring: Natural Granite Stone Finish and Nosing

Shall be 10mm thick x 300mm x 600mm (for steps) 10mm thick x 600mm x 600mm (for landing) matte finish anti-stain, homogenous porcelain tiles with heavy resistance to abrasion Class AAA, 7.5 kgs., green compliant by "Felpert International Marketing" or approved equal. Provide 2-3mm gap in between tile joint during installation. Granite Nosing shall be 18-20mm thick x 50mm premium quality natural granite stone in polished finish with medium to heavy resistance to abrasion by "Stefistone", "Joy Marble and Tiles", "Multi-Rich" or approved equal. Final color and pattern as per Architect's approved sample. Tile color and design shall be approved first before installation.

2.7.8 FF-10 Storage Room Flooring: Plain Cement Plaster Floor Finish with Epoxy Paint

Shall be plain cement smooth steel trowel finish with concrete hardener coated with a high performance, two component water-based acrylic epoxy paint which has a superior chemical, solvent and stain resistance, odorless and UV resistant finish. It has the further excellent of brushability and easy water clean-up by approved brand or approved equal. Submit color swatches of paints for Architect's approval. Verify structural drawings for slab thickness.

2.8 Wall Finishes

2.8.2 WF-2a Interior CHB Walls and Columns

Shall be 150mm thick/100mm thick CHB interior wall with 25mm thick smooth trowel cement plaster finish coated with high performance low VOC, odorless, ultra-premium water-based acrylic coating that gives a cleanable matte finish to walls and ceilings with surface protector and anti-bacterial protection by "Boysen Virtuoso Silk Touch" or approved equal. Submit color swatch and mock-up paint sample for Architect's approval

2.8.3 Interior Toilet Wall Finish 2 (Public Toilets):

2.8.3.1 Remaining Upper Wall:

Provide with 25mm thick smooth trowel cement plaster finish coated with high performance low VOC, odorless, ultra-premium water-based acrylic coating that gives a cleanable matte finish to walls and ceilings with surface protector and anti-bacterial protection for the remaining wall finish. Submit color swatch and mock-up paint sample for Architect's approval. Verify Toilet Details for the design.

For Urinal plumbing wall ledges provide 18-20mm thick x 200mm width premium high quality natural granite, medium to heavy resistance to abrasion. Verify Toilet Details for provisions and location of plumbing wall.

PART 3 EXECUTION

3.1 Comply with Manufacturer's standard installation procedures and applicable codes. Verify design and layout as approved from shop drawings submitted by Contractor in accordance to Drawings.

3.2 Examine surfaces to receive tile, before tile installation begins. Do not proceed with installation until adjoining work is satisfactorily protected. Correct the following conditions before proceeding with tile work.

3.2.1 Defects or conditions adversely affecting quality, execution and permanence of tile installation.

3.2.2 Maximum deviation of surfaces to receive tile:

A. Subfloor surface: ¼ inch in 10 feet

B. Vertical surface: ¼ inch in 8 feet

3.3 Condition of surfaces to receive tile shall be firm, dry, clean, and free of oily or waxy films. Grounds, anchors, lugs, hangers, recess frames, bucks, electrical and mechanical work in or behind tile to be installed prior to proceeding with tile installation.

3.4 Preparation

3.4.1 Mortar materials shall be measured in approved containers, which will insure that the specified proportions of materials will be controlled and accurately maintained during the progress of the work. Measuring materials with shovels, "shovel count", will not be permitted. Unless specified otherwise, mortar shall be mixed in proportions by volume, in approved mixing machines or mortar boxes. The quantity of water shall be controlled accurately and uniformly. The aggregates shall be introduced and mixed in such a manner that the materials will be distributed uniformly throughout the mass. A sufficient amount of water shall be added gradually and the mass further mixed in such a manner that the materials will be distributed uniformly throughout the mass. A sufficient amount of water shall be added gradually and the mass further mixed until a mortar of the plasticity necessary for purposes intended is obtained. Mortar boxes, pans, floor slabs and mixer's drums shall be kept clean and free from debris or dried mortar. Mortar shall be used before the initial setting of the cement has started to set will not be permitted. All mortar setting beds shall be mixed by volume in the proportion of 1 part Portland cement, 4 parts dry sand and ½ part lime.

3.5 Installation

3.5.1 Application of the flooring – Surfaces to receive the tile shall be clean, free of duct, dirt, oil, grease, and other deleterious substances. Floor tile operations in spaces receiving a wall tile shall not be started until wall tile installation has been completed. Before a tile is applied with a dry set mortar bed, the structural floor shall be tested for levelness or uniformity of the slope by flooding it with water. Areas where the water ponds shall be filled, leveled, and re-tested before the setting bed is applied.

A. Mortar setting beds shall be a minimum thickness of 20mm for floors, and 44mm for shower areas. The structural concrete slab shall be soaked thoroughly with clean fresh water on the day before the setting bed is to be applied. Immediately preceding the application of the setting bed, the structural slab shall again be wetted thoroughly, but no free water shall be permitted to remain on the surface. A skim coat of neat Portland cement mortar shall then be applied not less than 1.59mm thick. The mortar shall be spread until its surface is true and even and thoroughly compacted, either level or sloped uniformly for drainage, as the case required. A setting bed, as large as can be covered with tiles before the mortar has reached its initial set, shall be placed in the operation; but in the event that more setting mortar has been placed than can be covered, the unfinished portion shall be removed and cut back to a clean beveled edge.

- B. Application of tile flooring of Portland cement mortar. Tiles shall be soaked in water at least 12 hours before it shall be used. No free water shall remain on the tiles at the time of setting. A skim coat of neat Portland cement mortar, 0.79mm to 1.59mm thick shall be trowelled at or brushed over the setting bed and/ or the back of the tile, or a thin layer of Portland cement, 0.79mm to 1.59mm thick may be hand dusted uniformly over the setting bed and worked lightly with a trowel or brush until thoroughly damp. The tile shall then be pressed firmly upon the setting bed, and beaten into the mortar until true and even with the plane of the finished floor line. Beating and leveling shall be completed within one hour after placing the tile sheets. Borders and defined lines shall be laid before the field or body of the floor. Where floor drains are provided, the floors shall be sloping to drain properly to the drains. Intersection sand returns shall be formed accurately. Cutting of tiles where necessary, shall be done along the outer edges of the floors. As far as practicable, no tiles of less than half size shall be used. Tiles shall fit closely and neatly at all plumbing fixtures and around electrical outlets, pipes and fittings so those cover plates or escutcheons will overlap the tiles properly. Tiles shall be secured firmly in place and loose tiles or tiles sounding hollow shall be removed and replaced. All lines shall be kept straight, parallel, and true and even planes. The inner edge of borders shall be kept straight and where practicable, shall form right angles at all returns.

3.5.3 Grouting and Pointing

The tiles shall be wetted, if they have become dry, before applying grout. Joints of 3mm or less in width shall be routed with a neat white Portland cement grout of the consistency of thick cream. Other joints shall be pointed with mortar consisting of white Portland cement and two parts pointing sand. The grout or mortar for joints floors, walls and other vertical surfaces shall contain white Portland cement. Grout and pointing mortar shall be forced into joints by using trowel, squeegee, brush, or finger application. Before the grout or mortar sets, the joints of cushion-edge tiles shall be struck or tooled to the depth of the cushion, filling all skips or gaps, and the joints of a square-edge tile shall be filled completely flush with their surface. Dark cement shall not show through grouted white joints. Care shall be taken to avoid scratching glazed finishes. All surplus mortar or grout shall be removed before it has set or hardened.

3.5.4 Cleaning and Curing

Floors shall be covered with waterproofed paper with all joints lapped at least 100mm and the laps tape-sealed or held down with planks or other weights and allowed to damp-cure for at least 72 hours before foot traffic is permitted thereon. All completed tile work shall be thoroughly sponged and washed diagonally across joints, and finally polished with clean dry cloths. Acid cleaning unglazed tiles, when necessary, shall not be done within ten days after setting tiles. All metal shall be covered with approved grease and the tile wet with clean water before the tile is cleaned with a 10 percent muriatic-acid solution. After acid cleaning, the tile shall be flushed with clean water, and

grease coating on metal removed. Acid cleaners shall not be used on unglazed tiles.

3.5.5 Protection

Finished tile floors shall be covered with clean building paper before foot traffic is permitted on them. Board walkways shall be placed on floors that are to be continuously used as passageways by workers.

END OF SECTION

SECTION 09 90 00

PAINTS AND COATINGS

PART 1 GENERAL

1.1 SCOPE OF WORK

This section shall include all management, labor, materials, tools, equipment and services required to furnish and install paints and coatings as specified herein and shown in Drawings required to perform all works in accordance to the General conditions of the Contract Documents.

1.2 REFERENCES

Comply with quality assurance requirements under General conditions of the Contract Documents and Manufacturer's instructions. Reference the following standards as applicable:

- 1.2.1** ASTM D16-10 Standard Terminology for Paint, Related Coatings, Materials, and Applications
- 1.2.2** ASTM D3730-03 – Standard Guide for Testing High-Performance Interior Architectural Wall Coatings
- 1.2.3** ASTM D3960-05 – Standard Practice for Determining Volatile Organic Compound (VOC) Content of Paints and Related Coatings
- 1.2.4** ASTM D154 – 85(2009) Standard Guide for Testing Varnishes
- 1.2.5** ASTM D1652-04 Standard Test Method for Epoxy Content of Epoxy Resins
- 1.2.6** ASTM D3451-06 Standard Guide for Testing Coating Powders and Powder Coatings
- 1.2.7** U.S. Environmental Protection Agency (EPA) Reference Test Method 24, (Determination of Volatile Matter Content, Water Content, Density Volume

Solids, and Weight Solids of Surface Coatings), Code of Federal Regulations Title 40, Part 60, Appendix A.

1.3 SUBMITTALS

- 1.3.1** General: All submittals for approval as indicated herein shall be in accordance to the provisions under General Conditions of the Contract Documents.
- 1.3.2** Submit brochures or catalogs for the paint system to be used on the different surfaces to be applied for approval.
- 1.3.3** Material List: An inclusive list of required coating materials. Indicated each material and cross reference specific coating, finish system, and application. Identify each material by manufacturer's catalog number and general classification.
- 1.3.4** Manufacturer's Information: Manufacturer's technical information, including label analysis and instructions for handling, storing, and applying each coating material.
- 1.3.5** Selection Samples: For each finished product specified, two complete sets of color chips representing the manufacturer's full range of available colors and patterns.
- 1.3.6** Verification Samples: For each finish product specified, two samples, minimum size 150 mm square, representing actual product, color, and patterns.

1.4 QUALITY ASSURANCE

- 1.4.1** Comply with quality assurance requirements under General Conditions of the Contract Documents and Manufacturer's instructions.
- 1.4.2** Engage a reputable firm or manufacturer of paints and coatings similar in material, design, and extent to those indicated for this Project, whose work has resulted in applications with a record of successful service performance. Installer shall be trained by the same paint manufacturer or shall have significant experience with the application as specified herein.
- 1.4.3** Obtain block fillers and primers for each coating system from the same manufacturer as the finish coats.
- 1.4.4** Mock-up: Provide a mock-up for evaluation of surface preparation techniques and application workmanship.
 - A. Finish areas designated by the Architect.
 - B. Do not proceed with remaining work until workmanship, color, and sheen approved by the Architect.
 - C. Refinish mock-up area as required to produce acceptable work.

1.5 DELIVERY, STORAGE AND HANDLING

- 1.5.1** Comply with product delivery requirements under General Conditions of the Contract Documents and Manufacturer's instructions.
- 1.5.2** Paints and paint materials shall be delivered in sealed containers that plainly show the designated name, specification number, batch number, color, date of manufacture, manufacturer's directions and name of manufacturer. Storage of paints and paint materials and the mixing of paints shall be restricted to the locations directed.
- 1.5.3** Store materials in a dry, clean, well-ventilated area designated by the Architect for the storage of paint materials and tools. The storage space floor shall be adequately protected from damage and from paint. Paint shall be kept covered at all times and safeguarded to prevent fire.
- 1.5.4** Protect floors and all adjacent surfaces from paint smears, spatters, and dropping use drop-cloths to protect floors. Cover fixtures and remove hardware not to be painted. Mask off areas where necessary.
- 1.5.5** For safety precautions, the Contractor shall provide an appointed storage room with an ABC fire extinguisher throughout the duration of painting work. Foregoing fire extinguisher shall not be one required elsewhere in these specifications.

1.6 WARRANTY

Special written warranty for each material specified herein shall be submitted by Manufacturer/ Contractor without reducing or otherwise limiting any other rights to correction which the Owner may have under the Contract Documents. Failures are defined to include faulty workmanship or faulty materials.

1.7 PROJECT CONDITIONS

- 1.7.1** Comply with field examination requirements under General Conditions of the Contract Documents and Manufacturer's instructions.
- 1.7.2** Maintain environmental conditions (temperature, humidity, and ventilation) within limits recommended by the manufacturer for optimum results. Do not install products under environmental conditions outside manufacturer's absolute limits.

1.8 PERFORMANCE REQUIREMENTS

- 1.8.1** General: Standard coating terms defined in ASTM D 16 apply to this Section.
 - A. Flat refers to a lusterless or matte finish with a gloss range below 15 when measured at an 85-degree meter.
 - B. Eggshell refers to low-sheen finish with a gloss range between 5 and 20 when measured at a 60-degree meter.

- C. Satin refers to low-sheen finish with a gloss range between 15 and 35 when measured at a 60-degree meter.
- D. Semi-gloss refers to medium-sheen finish with a gloss range between 30 and 65 when measured at a 60-degree meter.
- E. High gloss refers to a high-sheen finish with a gloss range more than 65 when measured at a 60-degree meter.

1.8.2 The VOC concentrations of the product shall not exceed those listed below as determined by the U.S. Environmental Protection Agency (EPA) Reference Test Method 24 reference standard. Calculation of VOC to exclude water and tinting color added at the point sale.

Interior Coatings:

Coating Type	VOC weight in grams/liter of product minus water
Non-flat	150
Flat	50

Exterior Coatings:

Coating Type	VOC weight in grams/liter of product minus water
Non-flat	200
Flat	100

1.8.3 Aromatic Compounds: The product must contain no more than 1.0% by weight of the sum total of aromatic compounds.

PART 2 PRODUCTS

2.1 General: Comply with Manufacturer’s standard material requirements in conformity to the specifications herein.

2.1.1 Material Compatibility: Provide block fillers, primers, and finish-coat materials that are compatible with one another and with the substrates indicated under conditions of service and application, as demonstrated by manufacturer instructions based on testing and field experience.

2.1.2 All paints, thinners, linseed oils, and varnishes to be used shall be high quality painting systems, except as specified otherwise. All paints shall contain an effective amount of fungicide and mildew-proofing agent that shall prevent the paint from showing a mold growth or shall be inherently fungistatic by the nature of their constituents and shall be non-toxic to the person.

2.1.3 Acceptable Colors and Finishes: All color and finish selections shall be as specified herein and as approved by the Architect. Use neutral shades and minimal patterns as required.

2.2 Interior Masonry, Reinforced Concrete Wall & Slab, Dry Wall Partition and Ceiling

Shall be coated with high performance low VOC, odorless, ultra-premium water-based acrylic coating that gives a clean matte finish to walls and ceilings with surface protector and anti-bacterial protection. Painting schedule shall be:

- a. Allow new masonry to dry for 14 to 28 days under normal weather conditions. Surface to be painted should be clean and dry, free from oil, grease, dust, dirt, contaminants, and all loose grit and mortar.
- b. Treat new masonry with a solution of 1 part liquid acidic substance that is to be mixed with water to neutralize lime activity in new masonry surfaces, diluted in 16 parts water, applying liberally by brush or roller.
- c. Let it stand overnight before rinsing with water or rough sanding to remove white crystals that form on the surface. Let dry before painting.
- d. Primer coat –100% acrylic latex paint that's non-toxic, non-flammable, low-odor and has outstanding color retention. It contains the best fungicide to prevent mold and mildew growth.
- e. Full Putty/Spot Putty – a water based product especially prepared for filling minor surface unevenness
- f. Apply 2-3 coats of 100% acrylic water-based paint that is low odor, low VOC, lead free, and has outstanding color retention.

Follow manufacturer's standard application procedures. Submit color swatch and mock-up paint sample for Architect's approval.

2.3 Concrete Flooring

Shall be plain cement smooth trowel finish with concrete hardener coated with a high performance, two component water-based acrylic epoxy paint which has a superior chemical, solvent and stain resistance, odorless and UV resistant finish. It has the further excellent of brushability and easy water clean-up. Painting schedule shall be:

- a. 1 part of its curing.
- b. Reducer for primer
- c. 1 part of its curing agent.

Follow manufacturer's standard application procedure. Submit color swatch and mock-up paint sample for Architect's approval. Verify structural for slab thickness.

2.4 Metals

Shall be coated with high performance, two component water-based acrylic epoxy paint which has a superior chemical, solvent and stain resistance, odorless and UV resistant finish. It has further excellence of brushability and easy water clean-up. Painting schedule shall be:

- a. Primer – Red Oxide
- b. Reducer for Primer – Epoxy Reducer
- c. Topcoat

Follow manufacturer's standard application procedures. Submit color swatch and mock-up paint sample for Owner's approval upon the recommendation of the Architect.

2.5 Steel Doors

Shall be coated with solvent-free high ultra-violet resistant polyester powder-coating. Follow manufacturer's standard application procedures. Color as per Architect's approved sample.

2.6 Aluminum

Shall be coated with solvent-free high ultra-violet resistant polyester powder-coating. Follow manufacturer's standard application procedures. Color as per Architect's approved sample.

2.7 Masonry Neutralizer: Shall be acid-base concrete surface neutralizer.

2.8 Patching Compound Powder for sealing concrete and plaster: Shall be White Decalite type.

2.9 Sandpaper: Shall be waterproof type.

2.10 Trisodium Phosphate: Shall be used for removal of dirt, fungus, grease and oil shall be from concrete and plaster.

PART 3 EXECUTION

3.1 Comply with Manufacturer's instructions and standard installation requirements for each type of material.

3.2 Examination:

3.2.1 Do not begin installation until substrates have been properly prepared.

3.2.2 If substrate preparation is the responsibility of another installer, notify the Architect of unsatisfactory preparation before proceeding.

3.2.3 Coordination of Work: Review other Sections in which primers are provided to ensure compatibility of the total system for various substrates. On request, furnish information on characteristics of finish materials to ensure use of compatible primers.

3.2.4 Notify the Architect about anticipated problems when using the materials specified over substrates primed by others.

- 3.2.5** If a potential incompatibility of primers applied by others exists, obtain the following from the primer Applicator before proceeding:
- A. Confirmation of primer's suitability for expected service conditions.
 - B. Confirmation of primer's ability to be top coated with materials specified.
- 3.3** Material Preparation: Carefully mix and prepare coating materials according to manufacturer's written instructions.
- 3.3.1** Maintain containers used in mixing and applying coatings in a clean condition, free of foreign materials and residue.
- 3.3.2** Stir materials before applying to produce a mixture of uniform density. Stir as required during application. Do not stir surface film into the material. Remove film and, if necessary, strain coating material before using.
- 3.3.3** Use only the type of thinners approved by the manufacturer and only within recommended limits.
- 3.4** Workmanship shall be first class in every respect. Paint enamel and varnish finish shall be applied carefully with good clean brushes or approved rollers, or approved spraying equipment, except that the initial coat to be provided on any new or previously unpainted surface shall be painted brush. The work shall be so conducted as to avoid damage to other surfaces and public or private property in the area; any damage thereto shall be made good by the Contractor at his expense.
- 3.5** Installation: Apply paint according to manufacturer's written instructions. Use applicators and techniques best suited for substrate and type of material being applied.
- 3.5.1** Sufficient time shall be allowed between coats to ensure thorough drying, and each coat shall be in proper condition before the next coat is applied. Sanding and dusting, as required, to product finishes which are free from visible defects when viewed from a distance of 1.50m shall be performed. Varnish shall be sanded between coats.
- 3.5.2** Finish coat shall be smooth and free from runs, sags, or other defects. Each coat of paint shall be of sufficient thickness to cover completely the previous coat or surface. Exterior paint shall not be applied during rainy weather; the temperature shall be above 7°C and not over 35°C. Interior paint may be applied at any time provided the surfaces to be painted are dry and the temperature can be kept above 7°C during the application of ordinary paints, and between 18°C and 35°C during the application of enamels and varnishes.
- 3.5.3** Surfaces to be painted shall be thoroughly cleaned and except for cement-emulsion filler, shall be dry when the paint is applied. Interior areas shall be broom-cleaned and dust-free before and during the application of any painting materials.

- 3.5.4** Paint colors and finishes not specified shall be as approved. Surfaces which will be inaccessible after erection shall be treated and primed prior to erection, using two coats of the designated primer. Such inaccessible surfaces are defined as those surfaces that are concealed after erection or installation.
- 3.5.5** Surfaces of steel to be embedded in concrete shall not be painted. Succeeding coats of the same type and/ or color of paint shall vary sufficiently from the color of the preceding coat to permit ready identification. Damaged painting shall be retouched before the succeeding coat is applied. Finish surfaces shall be smooth, even, and free from defects. The number of paint coats specified shall be in addition to the shop priming coats.
- 3.5.6** Wood surfaces shall be free from dust and in an approved condition to receive the paint or varnish. The use of water on unpainted wood shall be avoided. Knots and resinous wood shall be treated with an application of knot sealer, prior to application of paint. Puttying of cracks and nail holes shall be done after the priming the coat has been applied and has dried properly. Sand-papering, when required, shall be done after the undercoats are dry.
- 3.5.7** Concrete and plaster shall be repaired before painting. Dirt, fungus, grease, and oil shall be removed prior to application of paint by washing the surfaces with a solution composed of from 2 to 8 ounces of tri-sodium phosphate per gallon of hot water and then rinsing thoroughly with fresh water. Efflorescence shall be removed from concrete and masonry surfaces by scraping, wire brushing, and washing with a 5 to 10 percent, by weight, solution of muriatic acid and then washing thoroughly with fresh water, removing all traces of the acid. The tri-sodium phosphate and muriatic acid solution shall be within the ranges specified and shall be of strengths to perform their functions properly. Glaze and all loose particles and scales are removed by wire brushing.
- 3.5.8** Puttying of concrete and plaster surfaces shall be done after the priming coat has been applied and has dried properly. Sand-papering will be required prior to the second coat of paint to provide an even and smooth surface.
- 3.5.9** Metal surfaces to be painted: as mentioned in other sections of these specifications including zinc-coated surfaces and unprimed steel and iron surfaces, immediately after being cleaned, shall be given one coat of pretreatment coating. Primer paint shall be applied over the pretreatment coating when practicable after the coating has dried. Powder coated installation needs no priming as per Manufacturer's instructions.
- 3.5.10** Wood, cement board or gypsum surfaces, interior and exterior painted surfaces except otherwise specified shall be given required finish as per Manufacturer's instructions. Prior to painting application, all nail holes and grains shall be puttied to even surfaces.
- 3.5.11** Pipe hangers, structural supports, pipe and pipe fittings, conduits and conduit fittings, and miscellaneous steel and iron work shall be painted as specified in accordance with ASME standards. Equipment shall be finished in accordance with the specification for the particular end item. Factory finished surfaces that are damaged during installation shall be restored to their original condition.

3.5.12 Other surfaces for which the type of paint has not been specified herein before shall be painted as specified for surfaces having similar conditions or exposure.

3.6 Cleaning

3.6.1 After completing painting, clean glass and paint splattered surfaces. Remove splattered paint by washing and scraping without scratching or damaging adjacent finished surfaces.

3.6.2 Wash cured lining using detergents and rinse thoroughly.

3.7 Protection

3.7.1 Protect work of other trades, whether being painted or not, against damage from painting. Correct damage by cleaning, repairing or replacing, and repainting, as approved by the Architect.

3.7.2 Provide “Wet Paint” signs to protect newly painted finishes. After completing painting operations, remove temporary protective wrappings provided by others to protect their work.

3.7.3 After work of other trades is complete, touch up and restore damaged or defaced painted surfaces.

END OF SECTION

SECTION 10 21 00

COMPARTMENT AND CUBICLES

PART 1 GENERAL

1.1 SCOPE OF WORK

This section shall include all management, labor, materials, tools, equipment and services required to manufacture, assemble, deliver (including all import and export documents), and install all items necessary for the proper execution and completion of toilet compartment and cubicles, as indicated in the General and Special Conditions of the Contract Documents, the drawings, as specified herein, and /or as required by job conditions.

1.2 REFERENCES

Comply with quality assurance requirements under General Conditions of the Contract Documents and Manufacturer’s instructions. The following standards form part of these specifications to the extent referenced:

1.2.1 National Building Code, NBC and BP 344 Accessibility Code

- 1.2.2 ASTM-E84 Standard Test Method for Surface Burning Characteristics of Building Materials
- 1.2.3 National Fire Protection Association, NFPA
- 1.2.4 ASTM B580 – 79 (2009) Standard Specification for Anodic Oxide Coatings on Aluminum
- 1.2.5 ANSI/ ASME A112.19.2M – American National Standard for Vitreous Porcelain Plumbing Fixtures

1.3 SUBMITTALS

- 1.3.1 General: All submittals for approval as indicated herein shall be in accordance to the provisions under General Conditions of the Contract Documents.
- 1.3.2 Submit manufacturer's data sheet to include, literature indicating typical panel, pilaster, door, hardware and fastening; storage and handling requirements; installation and maintenance methods.
- 1.3.3 Furnish shop drawings with dimensioned plans indicating the following:
 - A. Detailed layout of toilet partitions to include height of doors, pilasters, separation partitions, and other components.
 - B. Locations and sizes of openings in the compartment for toilet and bath accessories to be installed in partitions.
 - C. Floor and Ceiling clearances.
 - D. Details indicating anchoring components and bolt layouts. Indicate components required for installation, but not supplied by compartment and cubicle manufacturers.
- 1.3.4 Submit sample material for each finished product specified, one complete set of color guides representing the manufacturer's full range of available colors, textures and patterns for initial selections and two samples representing actual product, color, texture and pattern for verification prior approval.
- 1.3.5 Manufacturer's Certificates indicating that products meet or exceed specified requirements.

1.4 QUALITY ASSURANCE

- 1.4.1 Comply with quality assurance requirements under General Conditions of the Contract Documents and Manufacturer's instructions.
- 1.4.2 Manufacturer's Qualification

All primary products specified in this section will be supplied by a single manufacturer with a minimum of ten (10) years-experience.

1.4.3 Installer Qualification

All products listed in this section are to be mounted by a single installer with a minimum of one (1) year demonstrated experience in installing products of the same type and scope as specified.

1.4.4 Single Source Responsibility

Provide products of the same manufacturer for each type of accessory unit and for units exposed to view in the same areas, unless otherwise acceptable to the Architect.

1.4.5 Minimum smoke index of 40 and/or flame spread of 15 or less based on NFPA Standards.

1.5 DELIVERY, STORAGE AND HANDLING

Deliver partitions, hardware, and head rail in manufacturer's original protective shipping containers or packaging with labels intact and legible. Handle products carefully according to the manufacturer's instructions. Store compartment components until installation in unopened cartons laid flat, with adequate support to ensure flatness and to prevent damage to prefinished surfaces.

1.6 WARRANTY

Special written warranty for each material specified herein shall be submitted by Manufacturer/Contractor without reducing or otherwise limiting any other rights to correction which the Owner may have under the Contract Documents. Failures are defined to include faulty workmanship or faulty materials.

1.7 COORDINATION WITH OTHER TRADES

All installation, deliveries and other related works shall be coordinated with other trades to avoid interference in the construction.

1.8 PROJECT CONDITIONS

1.8.1 Comply with field examination requirements under General Conditions of the Contract Documents and Manufacturer's instructions.

1.8.2 Field measurements shall be taken prior to preparation of shop drawings and fabrication of toilet partitions to ensure proper fitting of work. Adjustments and enough time shall be allocated for such undertaking and right scheduling shall be made to avoid any delay of work.

1.8.3 Do not install products under environmental conditions outside manufacturer's absolute limits. Do not deliver materials or begin installation until the building is enclosed, with complete protection from outside weather.

PART 2 PRODUCTS

2.1 Floor Mounted Toilet Cubicle

2.1.1 Pilaster, Doors and Ledges Shall be 12mm thick compact laminated board doors in “69827 Sedan Oak” finish with pilasters resting on polyamide adjustable foot and anchored to the divisional walls by black anodized aluminum heavy duty U-channel, corner channel and top round channel, complete with accessories nylon coated (coat hook, door knob, privacy thumb turn, gravity hinge and door indicator lock) by approved brand or approved equal. Submit sample for Architect’s approval. Exposed surface, which exhibit pitting, seam marks, roller marks, stain, discolorations, telegraphing of core material or other imperfections on finished units shall not be accepted.

2.1.2 Channels, Rails and Brackets shall be heavy-duty extruded aluminum alloy 6063, channel with black anodized finish at the top rail.

2.1.3 Pilaster Anchor shall be polyamide adjustable foot metal standard with flanged top and bottom to screw fix to panel, adjustable with nylon flange to floor mounting and integral to door frame. Fixing of pilaster to the wall shall be done with black anodized heavy duty channel.

2.1.4 Hinges shall be three (3) black nylon coated units per door to match the aluminum section in size, stand-open, gravity rise and fall type.

2.1.5 Coat Hook, door knob, privacy thumb turn shall be of the manufacturer’s standard design, and system. Accessories shall be coated with black nylon resistant to heat, chemicals and bacteria.

2.2 Wall Mounted Urinal Partition

2.2.1 Pilaster Shall be 12mm thick compact laminated board partition in “69827 Sedan Oak” finish, anchored to the masonry or reinforced concrete walls by black anodized aluminum heavy duty nylon coated U-channel, corner channel and top round channel, complete with accessories by approved brand or approved equal. Submit sample for Architect’s approval. Exposed surfaces, which exhibit pitting, seam marks, roller marks, stain, discolorations, telegraphing of core material or other imperfections, on finished units shall not be accepted.

2.2.2 Channels shall be heavy-duty extruded aluminum alloy 6063, channel with black anodized finish.

2.3 Toilet Cubicle Ledge

Shall be 200mm width, 12mm thick compact laminated board ledge in “69827 Sedan Oak” finish complete with 25mm u-channel support and accessories. Submit sample for Architect’s approval.

PART 3 EXECUTION

3.1 Manufacturer’s Instructions

Comply with manufacturer’s product technical data, installation procedures and standards as per project requirement.

3.2 Fabrication

- 3.2.1 General: All doors, panels, screens, and pilasters shall be furnished and fabricated to match and fit in partition system, floor anchored or wall mounted of same construction and finish, unless otherwise indicated. Units shall be provided with cutouts, drilled holes and internal reinforcements to fit partition-mounted hardware and accessories. The standard total height of all toilet compartments and privacy screens shall be 1800mm.
- 3.2.2 Doors: Unless otherwise indicated, standard width opening of door for toilet the partition shall be 600mm wide and 900mm wide for toilets with handicap provisions.

3.3 Hardware and Fixing

- 3.3.1 All edges of doors and pilasters shall be chamfered and finished without any metal trimming.
- 3.3.2 All pilasters shall rest on a Nylon Coated adjustable foot “N-001 Adjustable Leg” and anchored to the division walls by satin anodized U-channel with a clearance of 150mm height.
- 3.3.3 Fixing of pilaster to the wall shall be done with black anodized Heavy Duty Channel.
- 3.3.4 Door Indicated Lock - Shall be nylon coated red/green color indicator for toilet doors.
- 3.3.5 Door Knob and Coat Hook – Shall be nylon coated N-003 Coat Hook and N-002 Door Knob
- 3.3.6 Urinal Bracket – Shall be nylon coated N-006 Urinal Bracket
- 3.3.7 Top Round Channel – Shall be nylon coated A-001 Top Round Channel and A-002 U Channel support stainless steel.
- 3.3.8 Hinge – Shall be nylon coated “N-005 Gravity Hinge”

3.4 Installation

- 3.4.1 General: Installation process shall comply with the manufacturer’s recommended procedures and methods. All partitions shall be rigid, straight, plumb and level when installed. Pilasters shall be fixed to the wall by square aluminum channels with stainless screw inserts. Aluminum channels shall be located so that holes for wall anchorages occur in masonry on tile joints. All panels shall be secured in position with the manufacturer’s recommended anchoring devices. All partitions shall be level with each other, and tightened with the proper devices. All doors shall be level with the pilasters when in closed position.
- 3.4.2 Floor Supported Partitions: Pilasters shall be supported with adjustable legs, with having not more than 25mm penetration into the structural floor, unless otherwise recommended by the manufacturer. All adjustable legs shall be fixed to the floor with stainless steel screws.

- 3.4.3** Screens: All privacy screens shall be attached to the wall with proper anchoring devices to suit supporting structure, as recommended by the manufacturer. All units shall provide support and resist lateral impact.

3.5 Adjustment and Cleaning

- 3.5.1** All hardware shall be adjusted and lubricated for proper operation. Hinges shall be set for swing-in doors to hold approximately 30 degrees from closed position when unlatched. Gravity hinges shall be used for swing-outdoors (and entrance swing doors) to return to fully closed position.
- 3.5.2** Exposed surface of the partition system shall be made clean using materials and methods recommended by the manufacturer. Protection shall be provided to prevent damage during the remainder of the construction period

END OF SECTION

SECTION 10 28 13

TOILET ACCESSORIES

PART 1 GENERAL

1.1 SCOPE OF WORK

This section shall include all management, labor, materials, tools, and equipment and services required to manufacture, assemble, deliver (including all import and export documents), and install all items necessary for the proper execution and completion of toilet accessories, as indicated in the General and Special Conditions of the Contract Documents, the Drawings, as specified herein, and/or as required by job conditions.

1.2 REFERENCES

The following standards form part of these specifications to the extent referenced, in accordance to the requirements under General Conditions of the Contract Documents and Manufacturer's instructions:

- 1.2.1** National Building Code, NBC
- 1.2.2** BP 344 Accessibility Code for mounting and installation standards
- 1.2.3** ASTM F446 – Consumer Safety Specification for Grab Bars and Accessories
- 1.2.4** ASTM C 1036 – Standard Specification for Flat Glass
- 1.2.5** ASTM D 1784 – Standard Specification for Rigid Poly Vinyl Chloride (PVC) Compounds and Chlorinated Poly Vinyl Chloride (CPVC) Compounds
- 1.2.6** ANSI/ ASME A 112.19.2M – American National Standard for Vitreous China Plumbing Fixtures

1.3 SUBMITTALS

Submit the following in accordance with the General Conditions of Contract and requirements specified herein:

- 1.3.1** Submit product data for each toilet accessory item specified, including construction details relative to materials, dimensions, gauges, profiles, mounting method, anchoring and fastening details specified options and finishes.
- 1.3.2** Submit setting drawings where cutouts are required in other work, including templates, substrate preparation instructions, and directions for preparing cutouts and installing anchorage devices. Locate each specified unit in project.
- 1.3.3** Operation and maintenance data.
- 1.3.4** Provide a mock-up for evaluation of installation techniques and layout. Finish areas designated by Architect. Do not proceed with remaining work until workmanship and layout are approved by Architect. Correct mock-up area as required to produce acceptable work.

1.4 QUALITY ASSURANCE

- 1.4.1** Comply with quality assurance requirements under General Conditions of the Contract Documents and Manufacturer's instructions.
- 1.4.2** Manufacturer's Qualification
Manufacturer shall have minimum of five (5) years documented experience producing requirements specified.
- 1.4.3** Single Source Responsibility
Provide products of same manufacturer for each type of accessory unit and for units exposed to view in same areas, unless otherwise acceptable to Architect.

1.5 DELIVERY, STORAGE AND HANDLING

Comply with the provisions under General Conditions of the Contract Documents and Manufacturer's instructions. Delivery of materials shall be so scheduled as to allow for immediate installation. Products shall be protected and kept under cover with manufacturer's standard protective packaging during transit and at the jobsite. Manufactured materials shall be delivered in the manufacturer's original unbroken packages or containers that are labeled plainly with the manufacturer's name and brands. Materials shall be stored in any weather-tight enclosures, and shall be handled in a manner that will prevent damage until installation.

1.6 WARRANTY

Special written warranty for each material specified herein shall be submitted by Manufacturer/ Contractor without reducing or otherwise limiting any other rights to correction which the Owner may have under the Contract Documents. Failures are defined to include faulty workmanship or faulty materials.

1.7 COORDINATION WITH OTHER TRADES

Ensure that locating templates and other information required prior installation of materials under this section is furnished in time to affected trades to prevent interruption of construction progress.

1.8 PROJECT CONDITIONS



Comply with field examination requirements under General Conditions of the Contract Documents and Manufacturer’s instructions.

Maintain environmental conditions including temperature, humidity, and ventilation, within limits recommended by manufacturer for optimum results. Do not install products under environmental conditions outside manufacturer’s absolute limits.

PART 2 PRODUCTS

2.1 Tissue Paper Holder 1

2.1.1 Shall be Grade A white vitreous china, semi-recessed wall-mounted tissue paper holder. Submit brochures and sample for Architect’s approval.

SCHEDULE:	
<p>OPTION 1:</p> <p>Dimensions: L151mm x W72mm x H151mm</p> <p>“HCG - S8” or approved equal.</p> 	<p>OPTION 2:</p> <p>Dimensions: 165mm x 165mm</p> <p>“American Standard - Standard 9002” or approved equal.</p> 

2.2 Tissue Paper Holder 2

Shall be anchored to Partition Wall, shall be black PV nylon-coated, wall-mounted tissue paper holder with lid cover and concealed screws by approved brand or approved equal.

SCHEDULE:



2.3 Liquid Soap Dispenser

Shall be 155mm x 100mm x 73mm manual push type, stainless steel liquid soap dispenser in satin finish with 800ml liquid content. Submit brochures and samples for Architect's approval.

PART 3 EXECUTION

3.1 Manufacturer's Instruction

Comply with manufacturer's product technical data, installation procedures and standards as per project requirement.

3.2 Field Examination

3.2.1 Installer shall examine conditions under which construction activities are to be performed, then submit written notification if such conditions are acceptable.

3.2.2 Verify that accessories are installed and in the right location without interference with piping, fittings and fixture.

3.2.3 Surfaces must be clean, dry and free from dust, dirt, grease and loose or powdery material. Do not begin installation until substrates have been properly prepared.

3.3 Installation

3.3.1 Install toilet accessories plumb and level in accordance with shop drawings and manufacturer's printed installation instructions. Installed heights shall be as shown on the drawings and in accordance to the provisions of the Accessibility Code.

3.3.2 Secure mirrors to walls in concealed, tamper-resistant manner using tile adhesive or mirror mastic with sponge tape. Set units level, plumb, and square at locations indicated, according to manufacturer's written instructions for substrate indicated.

3.3.3 Surface of fastening devices exposed after installation shall have the same finish as the attached accessory.

3.4 Protection

All installations shall be protected with coverings as per manufacturer's recommended material. Replace damaged or defective items caused by subsequent construction activities.

3.5 Adjusting and Cleaning

3.5.1 Verify that mechanisms function properly and adjust accessories as per required installations.

3.5.2 Remove temporary labels and protective coatings. Clean and polish exposed surfaces according to manufacturer's written recommendations.

END OF SECTION

OUTLINE SPECIFICATIONS

DIVISION 1 – GENERAL REQUIREMENTS

General. It is declared and acknowledged intention and meaning to provide and secure the **Lobby Area and Breakout Rooms of the UPOU International Convention Center** located at **UP Open University (UPOU) Campus, Los Baños, Laguna**, complete and ready for use.

1.1 Complete Finishes

1.2 Complete Temporary Facilities

1.3 Complete Support Utilities (Field Office/Storage etc.)

1.4 Complete Supply of Health, Safety and Security

1.5 Supply and Installation of Project Signs, complete

1.6 Contractor's Tax

DIVISION 2 – EXISTING CONDITIONS

DIVISION 3 – CONCRETE WORKS

DIVISION 4 – MASONRY WORKS

Repair/Replastering of wall plastering defects: 25mm thick smooth trowel cement plaster finish, bonded to the existing CHB wall/substrate using a styrene-acrylic admixture product, coated with plain finish semi-gloss high performance low voc, odorless, ultra-premium, water-based acrylic coating that gives a cleanable matte finish to walls and ceilings with surface protector and anti-bacterial protection. Provide high-performance acrylic skimcoat to interior wall to achieve an even and smooth concrete surface before applying paint primer.

DIVISION 5 – METAL WORKS

5.2 METAL RAILING

5.2.1 Main Staircase Railing and Viewing Balcony Railing

Shall be 42mm outside diameter, grade 304, stainless steel tubular handrail in hairline finish with 10mm x 40mm flat bar vertical balustrade, fully doweled to concrete zocalo at every 1950mm, coated with high performance two component solvent-based epoxy enamel paint finish; with 10mm x 40mm flat bar horizontal support balustrade, coated with high performance two component solvent-based epoxy enamel paint finish. Submit shop drawings, mock-up layout and sample for Architect's approval. Refer to Architectural drawings for layout and details.

Dismantling of existing tubular handrails and installation of new 42mm outside diameter, Grade 304, Stainless Steel Tubular Handrail in hairline finish.

Existing 10mm x 40mm flat bar vertical balustrade shall be applied with rust remover and rust converter and shall be coated with high performance two component solvent-based epoxy enamel paint finish; with 10mm x 40mm flat bar horizontal support balustrade, coated with high performance two component solvent-based epoxy enamel paint finish.

DIVISION 8 – OPENINGS

8.1 DOORS

Note: Dimension, fabrication and installation of Doors shall be based on the actual measurements and conditions of the site. Verify Manufacturer's standard details. Submit shop drawings and sample for Architect's approval.

8.1.1 STEEL DOORS AND FRAMES

Note: All existing Steel Door on site shall be in powder-coated finish, submit swatches for Architect's approval.

A. Steel Door

Location:

D-10a (Chairs & Tables Storage Rm 3)

Shall be 1.3mm thick, gauge 18 base metal thickness, 45mm thick, cold rolled steel door, made of chromate-free electro galvanized steel sheet with zinc coating layer applied on base metal and honeycomb core insulation. Framing shall be fully-welded, 1.6mm thick, gauge 16 x 45mm x 140mm single rabbet, hollow metal frames of the same door panel material by approved brand or approved equal; door finish shall be in a powder-coated finish. Complete with hardware and accessories (see Division 8.5 Hardware for specifications). Follow manufacturer's standard installation procedures. Submit sample color finish and sample section for Architect's approval.

B. Steel Door with Bottom Louvers

Location:

D-14b (Female Toilet 4)

Shall be 1.3mm thick, gauge 18 base metal thickness, 45mm thick, powder-coated finish, cold rolled steel door with 1.2mm thick GA. 18 x 45mm x 75mm Z profile bottom louver blades, made of chromate-free

electro galvanized steel sheet with zinc coating layer applied on base metal and honeycomb core insulation. Framing shall be fully-welded, 1.6mm thick, gauge 16 x 45mm x 140mm single rebate, hollow metal frames of the same door panel material, complete with hardware and accessories; door finish shall be in powder-coated finish. Follow manufacturer's standard installation procedures. Submit color finish for Architect's approval.

C. **Acoustical Steel Door**

Location:

D-17b (Breakout Room 1 & 4; Breakout Room 2 & 3)

Shall be 1.6mm thick, gauge 16 base metal thickness, 45mm thick, cold rolled steel door, made of chromate-free electro galvanized steel sheet with zinc coating layer applied on base metal and filled in with sound absorbing material (fiberglass/rockwool on honeycomb insulation) with perimeter seal. Framing shall be fully welded, 1.6mm thick, gauge 16 x 45mm x 140mm single rebate, hollow metal frames of the same door panel material. Complete with vertical pull handles (back to back), hardware, concealed door closer, standard rim cylinder, jamb and head seal, threshold, automatic door bottom, meeting stile seal and accessories, door finish shall be in stainless steel Grade 304, hairline finish (No. 4 finish). Follow manufacturer's standard installation procedures. Submit sample color finish, sample swatches and sample section for Architect's approval.

8.2 **MIRRORS**

8.2.1 *Facial Mirror at Male and Female Toilets*

Shall be 6mm thick frameless, silver-coated float glass mirror with 2mm thick chamfered edges on both sides, glued to 12mm thick marine plywood backing and 25mm x 50mm TKD Tanguile framing using tile adhesive or mirror mastic with sponge tape on one side, facing wall by approved brand or approved equal. Provide screws with expansion shield and chrome-plated screw cap. Refer to Architectural Drawing for dimension, layout and design.

8.4 **BUILDER'S HARDWARE**

Note: Submit hardware samples and product catalog for Architect's approval, before purchasing and installation of the material.

8.4.1 **Manual Flush Bolt for Steel Doors**

Shall be UL listed manual flush bolt made from brass faceplate with steel component. Bolt shall be set on inactive door of a pair with 25mm x 172mm face plate and 13mm standard threaded rod size in satin chrome finish (US26D) with 3-hour fire rating for metal doors complying to ANSI 156.16 for L14251. Submit sample for Architect's approval.

8.4.2 **One-Way Deadbolt Lock (no locking from the inside)**

Shall be UL listed deadbolt lock, made from high strength steel alloy deadbolt lock with maximum security cylinder retracted by key outside and blank plate

with exposed screws inside, complying to ANSI/BHMA A156.5-2001, Grade 1 Lock in satin chrome finish. Provide patented tough nickel silver key.

8.4.3 Hinges – Ball Bearing Hinges

Shall be four (4) pieces, UL listed five knuckle ball bearing hinges made from stainless steel material with stainless steel pin, complying with ANSI A5112 and ANSI A2112, in satin chrome finish (US26D).

8.4.4 Vertical Pull Handle (for Acoustical Steel Doors)

1.2mm thick, 25mm diameters x 1760mm/1800mm length, stainless steel, back to back, vertical pull handle complying with ISO9001 (Architectural Hardware) in satin chrome finish.

8.4.5 Locksets

Lever Type Lockset

Grade 1, UL listed, exceeds ANSI/ BHMA certified A 156.2, entrance function high security cylindrical lock with thru-bolted mechanism, concealed mounting screws and independent heavy-duty spring cages for lever support. Provide dummy trim for double doors and patented tough nickel silver key.

8.4.6 Concealed Door Closer

Grade 1, UL listed, ANSI standard A156.4, high strength concealed closer made from combination of cast iron bodied closers “oversized” hardened steel pistons and forged steel arms, complete with closing and latching speed hold open points adjusted.

8.4.7 Door Stop 1 (steel doors)

UL listed, meets ANSI/BHMA A156.16, casted aluminum in satin chrome finish with rubber tip door stop.

8.4.8 Door Coordinator

Grade 1, UL listed, ANSI standard A156.4

DIVISION 9 – FINISHES

9.1 CEILINGS

9.1.1 General Ceilings: Gypsum Boards Ceiling Finish

Shall be coated with high performance low VOC, odorless, ultra-premium water-based acrylic coating that gives a cleanable matte finish to walls and ceilings with surface protector and anti-bacterial protection by approved brand or approved equal.

9.2 FLOORING

9.2.1 General Flooring: Polished Finish Homogenous Porcelain Tiles (FF-4)

Shall be 10mm thick x 600mm x 600mm double polished finish anti-stain, homogenous porcelain tiles with heavy resistance to abrasion Class AAA, 7.5 kgs. by approved brand or approved equal. Final color and pattern as

per Architect's approved sample. Provide 2-3 mm gap in between tile joint during installation. Tile color and design shall be approved first before installation.

9.2.2 ***Main Stairs Flooring: Natural Granite Stone Finish and Nosing (FF-8)***

Shall be 10mm thick x 300mm x 600mm (for steps) 10mm thick x 600mm x600mm (for landing) matte finish anti-stain, homogenous porcelain tiles with heavy resistance to abrasion Class AAA, 7.5 kgs., green compliant by approved brand or approved equal. Provide 2-3mm gap in between tile joint during installation. Granite Nosing shall be 18-20mm thick x 50mm premium quality natural granite stone in polished finish with medium to heavy resistance to abrasion by approved brand or approved equal. Final color and pattern as per Architect's approved sample. Tile color and design shall be approved first before installation.

9.2.3 ***Storage Room Flooring: Plain Cement Plaster Floor Finish with Epoxy Paint (FF-10)***

Shall be plain cement smooth steel trowel finish with concrete hardener coated with a high performance, two component water-based acrylic epoxy paint which has a superior chemical, solvent and stain resistance, odorless and UV resistant finish. It has the further excellent of brushability and easy water clean-up by approved brand or approved equal. Submit color swatches of paints for Architect's approval. Verify structural drawings for slab thickness.

9.2.4 ***Natural Granite Stone Nosing 2: Interior Floor Termination***

Shall be 18-20mm thick x 50mm/100mm premium high quality natural granite stone in polished finish with medium to heavy resistance to abrasion by approved brand or approved equal, final color and pattern as per Architect's approved sample.

9.2.5 ***Natural Granite Stone Nosing 3: Interior Floor Termination and Toilet Entry Floor Nosing***

Shall be 18-20mm thick x 50mm/150mm premium high quality natural granite stone in polished finish with medium to heavy resistance to abrasion by approved brand or approved equal, final color and pattern as per Architect's approved sample.

9.3 **WALL FINISHES**

9.3.1 ***Interior Wall Finish 1: Concrete Hollow Blocks (WF-2a)***

Existing interior CHB wall with 25mm thick smooth trowel cement plaster finish shall be coated with high performance low VOC, odorless, ultra-premium water-based acrylic coating that gives a cleanable matte finish to walls and ceilings with surface protector and anti-bacterial protection by approved brand or approved equal. Submit color swatch and mock-up paint sample for Architect's approval.

9.3.2 ***Interior Dry Wall Partition Finish: Gypsum Board Dry Wall Partition (WF-2b)***

Shall be 12mm thick square edge, sag resistant regular gypsum board with ivory face paper, shall be coated with high performance low VOC, odorless, ultra-premium water-based acrylic coating that gives a cleanable matte finish to walls and ceilings with surface protector and anti-bacterial protection.

Replacement of rusted framing. Framing shall be 0.60mm thick gauge 24 x 35mm x 76mm galvanized light steel top and bottom tracks and 0.60mm gauge 24 x 35mm x 76mm vertical and horizontal studs spaced at 600mm both ways, complete with screws, accessories and 0.40mm gauge 26 x 25mm x 25mm corner bead with BPS (Bureau of Product Standards) certification.

Provide 32 kg/cum 50mm thick lightweight, flexible and resilient insulation board (acoustic fiberglass insulation) made of long fine glass fibers bonded with thermosetting resin and reflective aluminum foil vapor barrier by approved brand or approved equal.

9.3.3 ***Existing remaining upper CHB wall***

Shall be 25mm thick smooth trowel cement plaster finish coated with high performance low voc, odorless, ultra-premium water-based acrylic coating that gives a clean matte finish to walls and ceilings with surface protector and anti-bacterial protection for the remaining wall finish. (Location: Public Toilets)

9.3.4 ***Dry Wall Partition Finish (temporary): Gypsum Board DryWall Partition (WF-2d)***

Shall be 9mm thick standard plasterboard on 0.60mm thick gauge 26 x 35mm x 76mm galvanized light steel top and bottom tracks, set in place with construction adhesive and 0.40mm gauge 26 x 35mm x 76mm vertical and horizontal studs spaced at 1000mm both ways, complete with screws, accessories, coated with high performance low voc, odorless, ultra-premium water-based acrylic coating that gives a cleanable matte finish to walls and ceilings with surface protector and anti-bacterial protection. Submit color swatch and mock-up paint sample for architect's approval.

9.3.5 ***Existing Toilet Doors***

Door finish shall be coated with semi-gloss polyurethane paint finish. Submit color swatch and mock-up paint sample for architects's approval.

DIVISION 10 – SPECIALTIES

10.2 Compartments and Cubicle

10.2.1 Toilet Cubicle Door with Partition

Shall be 12mm thick compact laminated board doors in “69827 Sedan Oak” finish with pilasters resting on polyamide adjustable foot and anchored to the divisional walls by black anodized aluminum heavy duty U-channel, corner channel and top round channel, complete with accessories nylon coated (coat hook, door knob, privacy thumb turn, gravity hinge and door indicator lock) by approved brand or approved equal. Submit sample for Architect’s approval.

10.2.2 *Urinal Partitions*

Shall be 12mm thick compact laminated board partition in “69827 Sedan Oak” finish, anchored to the masonry or reinforced concrete walls by black anodized aluminum heavy duty nylon coated U-channel, corner channel and top round channel, complete with accessories by approved brand or approved equal. Submit sample for Architect’s approval.

10.2.3 *Toilet Cubicle Ledge*

Shall be 200mm width, 12mm thick compact laminated board ledge in “69827 Sedan Oak” finish complete with 25mm u-channel support and accessories by approved brand or approved equal. Submit sample for Architect’s approval.

10.3 **TOILET AND BATH ACCESSORIES**

10.3.1 ***TOILET ACCESSORIES***

10.3.1.1 *Tissue Paper Holder 1*

Shall be Grade A white vitreous china, semi-recessed wall-mounted tissue paper holder by approved brand or approved equal. Submit brochures and samples for Architect’s approval.

10.3.1.2 *Tissue Paper Holder 2*

Shall be anchored to the Partition Wall, shall be black PV nylon-coated, wall-mounted tissue paper holder with lid cover and concealed screws by approved brand or approved equal. Submit brochures and samples for Architect’s approval.

10.3.1.3 *Liquid Soap Dispenser*

Shall be 155mm x 100mm x 73mm manual push type, stainless steel liquid soap dispenser in satin finish with 800ml liquid content. Submit brochures and samples for Architect’s approval.

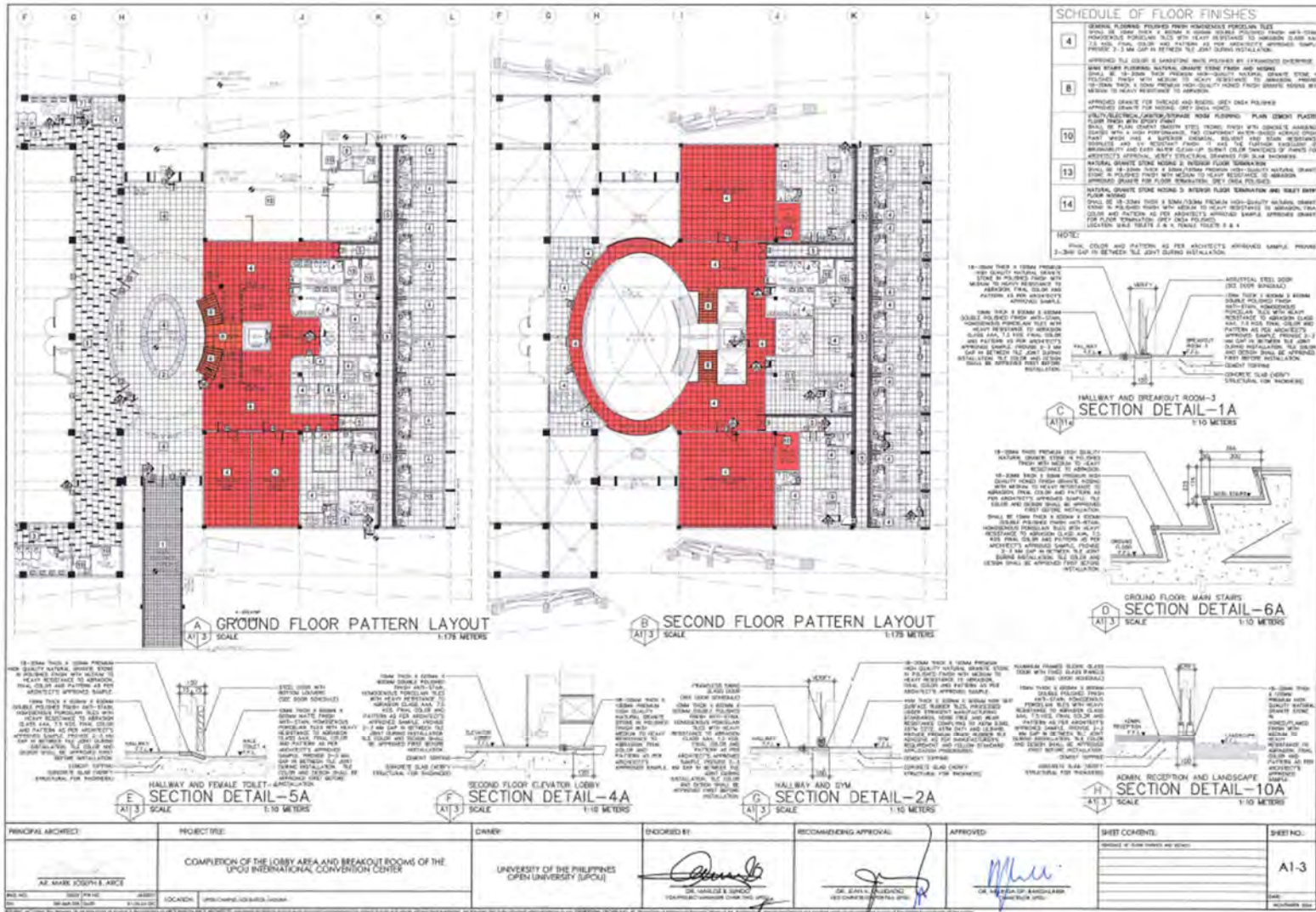

SCHEDULE OF FLOOR FINISHES

- 4** GENERAL FLOORING FINISHED FLOOR FINISHES PER ARCHITECT'S APPROVAL. SEE ARCHITECT'S APPROVAL. APPROVED DRAWING FOR FINISHES. SEE ARCHITECT'S APPROVAL.
- 8** APPROVED GRANITE FOR THROUGH AND BENCH. SEE ARCHITECT'S APPROVAL. APPROVED DRAWING FOR FINISHES. SEE ARCHITECT'S APPROVAL.
- 10** POLYURETHANE POLISHED FLOOR FINISHES PER ARCHITECT'S APPROVAL. APPROVED DRAWING FOR FINISHES. SEE ARCHITECT'S APPROVAL.
- 13** NATURAL QUARTZ STONE SLAB. APPROVED GRANITE FOR THROUGH AND BENCH. SEE ARCHITECT'S APPROVAL. APPROVED DRAWING FOR FINISHES. SEE ARCHITECT'S APPROVAL.
- 14** NATURAL QUARTZ STONE SLAB. APPROVED GRANITE FOR THROUGH AND BENCH. SEE ARCHITECT'S APPROVAL. APPROVED DRAWING FOR FINISHES. SEE ARCHITECT'S APPROVAL.

NOTE:
FINISH COLOR AND PATTERN AS PER ARCHITECT'S APPROVED SAMPLE BOARD. 2-3MM GAP IN BETWEEN TILE JOINT DURING INSTALLATION.

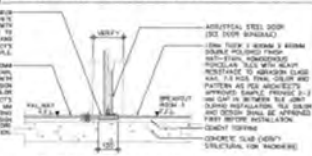

**HALLWAY AND BREAKOUT ROOM-3
SECTION DETAIL-1A**
SCALE: 1/10 METERS

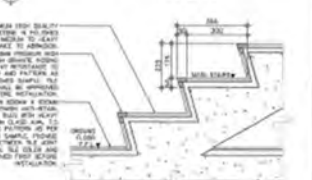

**GROUND FLOOR MAIN STAIRS
SECTION DETAIL-6A**
SCALE: 1/10 METERS

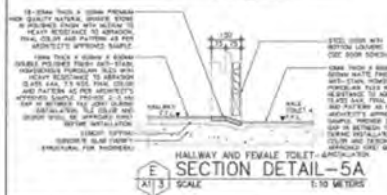

**HALLWAY AND FEMALE TOILET-5A
SECTION DETAIL-5A**
SCALE: 1/10 METERS

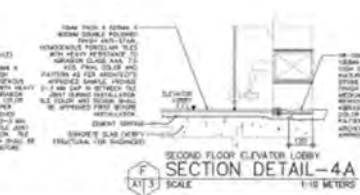

**SECOND FLOOR ELEVATOR LOBBY
SECTION DETAIL-4A**
SCALE: 1/10 METERS

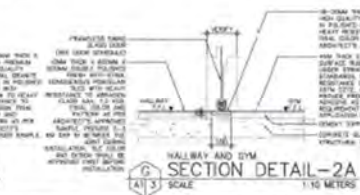

**HALLWAY AND GYM
SECTION DETAIL-2A**
SCALE: 1/10 METERS

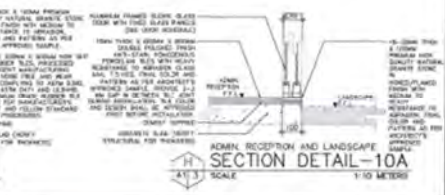

**ADMIN RECEPTION AND LANDSCAPE
SECTION DETAIL-10A**
SCALE: 1/10 METERS

PRINCIPAL ARCHITECT:	PROJECT TITLE:	OWNER:	ENDORSED BY:	RECOMMENDING APPROVAL:	APPROVED:	SHEET CONTENTS:	SHEET NO.:
DR. MARK JOSEPH S. ARCE	COMPLEX OF THE LOBBY AREA AND BREAKOUT ROOMS OF THE UPON INTERNATIONAL CONVENTION CENTER	UNIVERSITY OF THE PHILIPPINES OPEN UNIVERSITY (UPOU)	DR. MARCELO B. SANCHEZ	DR. JAY R. CALIBANGAN	DR. MARCELO B. SANCHEZ		A1-3

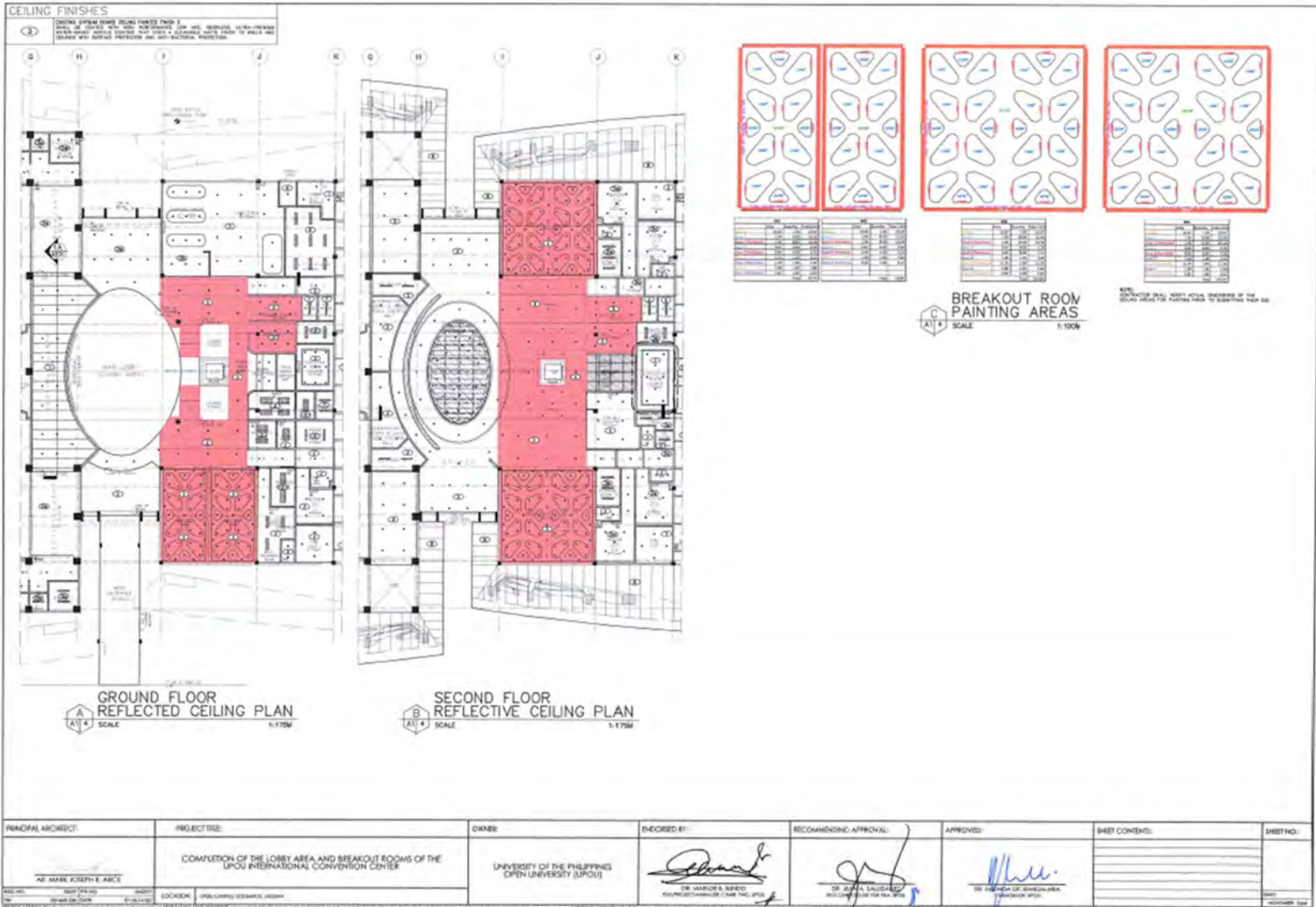

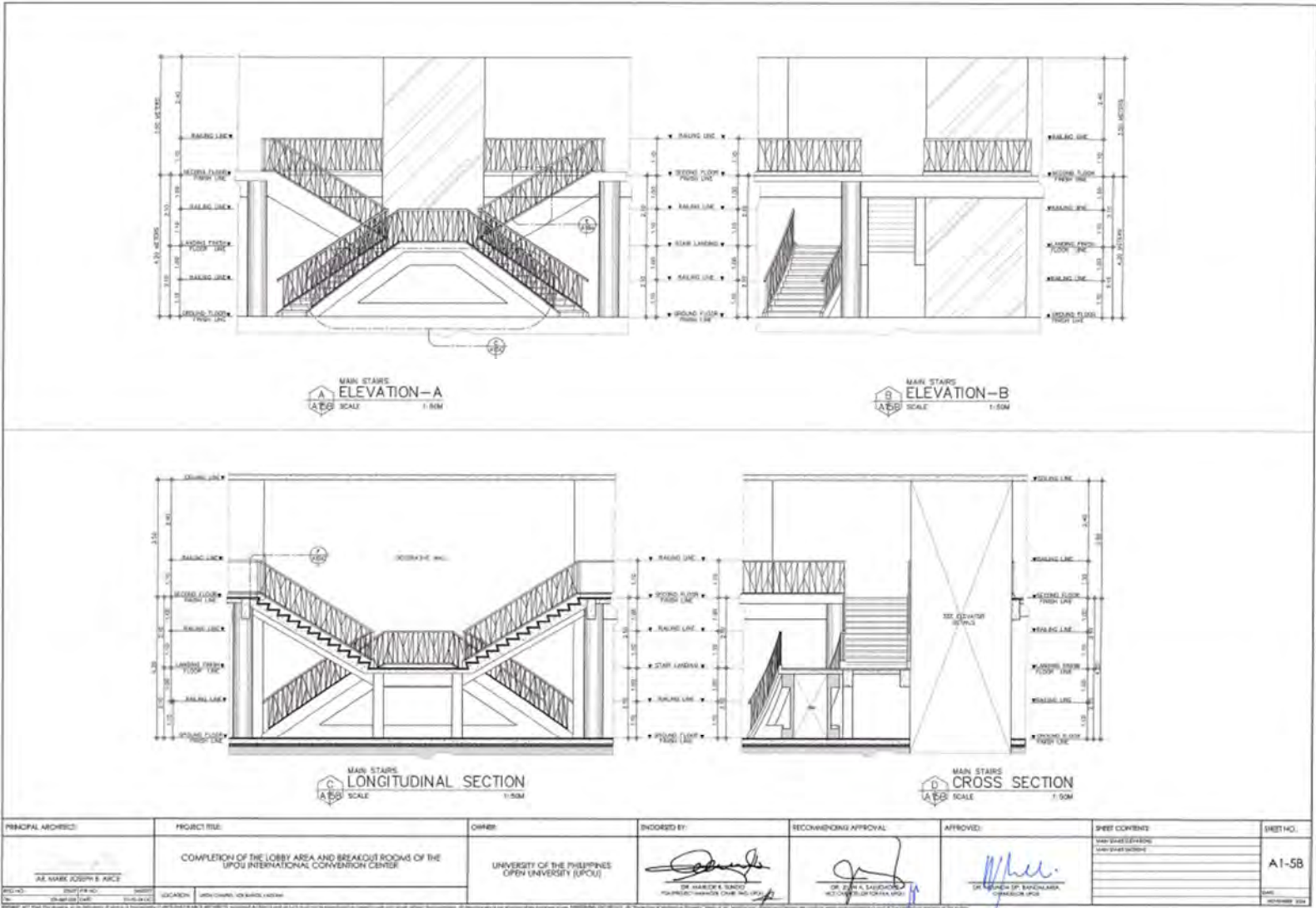

PRINCIPAL ARCHITECT	PROJECT TITLE	OWNER	DESIGNED BY	RECOMMENDING APPROVAL	APPROVED	SHEET COVERS	SHEET NO.
AR. MARK JOSEPH B. ARCE	COMPLETION OF THE LOBBY AREA AND BREAKOUT ROOMS OF THE UPOU INTERNATIONAL CONVENTION CENTER	UNIVERSITY OF THE PHILIPPINES OPEN UNIVERSITY (UPOU)	DR. MARIE K. TAYO PROJECT ARCHITECT	DR. ZENY A. SAGUNDO REGISTERED ARCHITECT	DR. MARICELA P. BANGALANA REGISTERED ARCHITECT	MAIN STAIRS ELEVATION-A MAIN STAIRS ELEVATION-B MAIN STAIRS LONGITUDINAL SECTION MAIN STAIRS CROSS SECTION	A1-5B

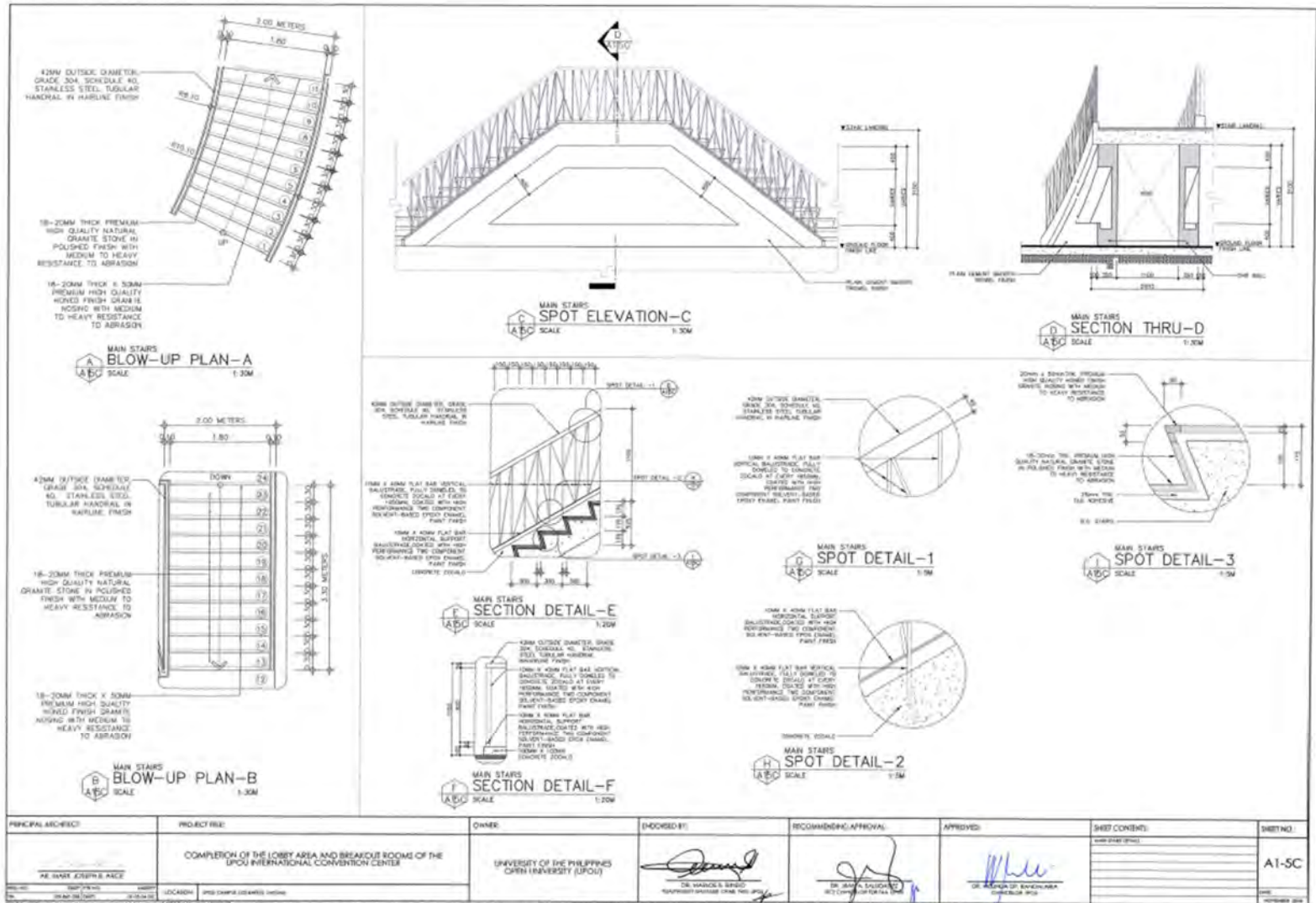

PRINCIPAL ARCHITECT	PROJECT FILE	OWNER	CHECKED BY:	RECOMMENDING APPROVAL	APPROVED:	SHEET CONTENT:	SHEETING:
DR. JAMES C. RIVERA	COMPLETION OF THE LOBBY AREA AND BREAKOUT ROOMS OF THE UPOU INTERNATIONAL CONVENTION CENTER	UNIVERSITY OF THE PHILIPPINES (UPOU)	DR. MARCEL B. BARRERA	DR. JAMES C. RIVERA	DR. MARCEL B. BARRERA	SHEET NO. 01 SHEET NO. 02 SHEET NO. 03 SHEET NO. 04 SHEET NO. 05 SHEET NO. 06 SHEET NO. 07 SHEET NO. 08 SHEET NO. 09 SHEET NO. 10 SHEET NO. 11 SHEET NO. 12 SHEET NO. 13 SHEET NO. 14 SHEET NO. 15 SHEET NO. 16 SHEET NO. 17 SHEET NO. 18 SHEET NO. 19 SHEET NO. 20 SHEET NO. 21 SHEET NO. 22 SHEET NO. 23 SHEET NO. 24 SHEET NO. 25 SHEET NO. 26 SHEET NO. 27 SHEET NO. 28 SHEET NO. 29 SHEET NO. 30 SHEET NO. 31 SHEET NO. 32 SHEET NO. 33 SHEET NO. 34 SHEET NO. 35 SHEET NO. 36 SHEET NO. 37 SHEET NO. 38 SHEET NO. 39 SHEET NO. 40 SHEET NO. 41 SHEET NO. 42 SHEET NO. 43 SHEET NO. 44 SHEET NO. 45 SHEET NO. 46 SHEET NO. 47 SHEET NO. 48 SHEET NO. 49 SHEET NO. 50 SHEET NO. 51 SHEET NO. 52 SHEET NO. 53 SHEET NO. 54 SHEET NO. 55 SHEET NO. 56 SHEET NO. 57 SHEET NO. 58 SHEET NO. 59 SHEET NO. 60 SHEET NO. 61 SHEET NO. 62 SHEET NO. 63 SHEET NO. 64 SHEET NO. 65 SHEET NO. 66 SHEET NO. 67 SHEET NO. 68 SHEET NO. 69 SHEET NO. 70 SHEET NO. 71 SHEET NO. 72 SHEET NO. 73 SHEET NO. 74 SHEET NO. 75 SHEET NO. 76 SHEET NO. 77 SHEET NO. 78 SHEET NO. 79 SHEET NO. 80 SHEET NO. 81 SHEET NO. 82 SHEET NO. 83 SHEET NO. 84 SHEET NO. 85 SHEET NO. 86 SHEET NO. 87 SHEET NO. 88 SHEET NO. 89 SHEET NO. 90 SHEET NO. 91 SHEET NO. 92 SHEET NO. 93 SHEET NO. 94 SHEET NO. 95 SHEET NO. 96 SHEET NO. 97 SHEET NO. 98 SHEET NO. 99 SHEET NO. 100	A1-SC

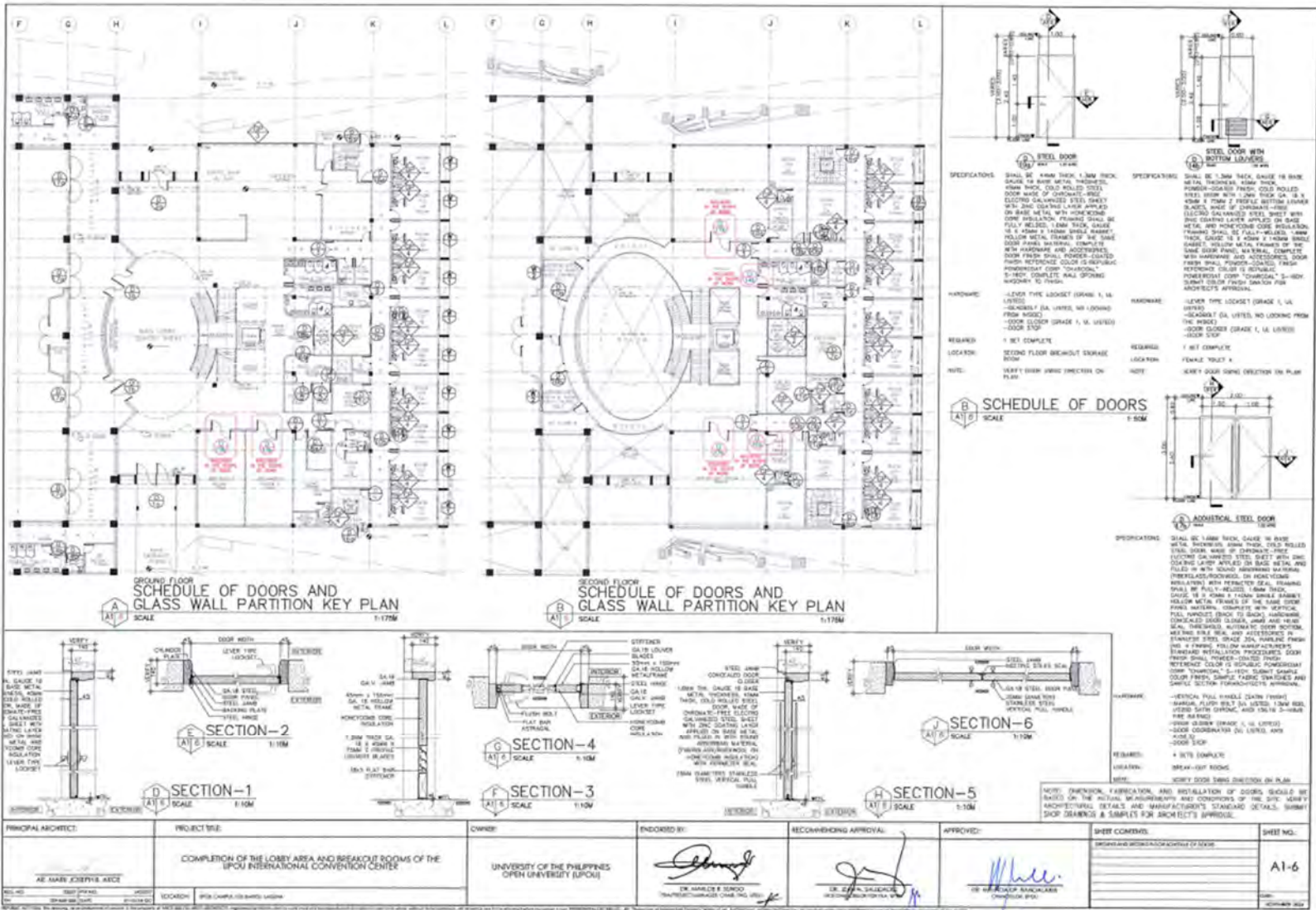

(A) STEEL DOOR
 SPECIFICATIONS: SHALL BE 4MM THICK, 1.5M THICK GAUGE 18 BARE METAL THICKNESS 4MM THICK POWDER-COATED FINISH, COLORED ROLLED STEEL SHEET WITH 2 PLYS OF POLYURETHANE INSULATION ON BASE METAL WITH HONEYCOMB CORE INSULATION FINISHING SHALL BE FULLY WELDED, LEAK TIGHT GAUGE IS 4.5MM X 1.5MM SINGLE RIBBON YELLOW METAL FRAMES OF THE SAME GAUGE SHALL BE WELDED TO THE FRAME WITH HARDWARE AND ACCESSORIES FROM FINISH SHALL POWDER-COATED FINISH REFERENCE COLOR IS REFERENCE POWDER COAT "CONCRETE" 5-YEAR WEAR COMPLETE WALL SPACING MODULAR TO FINISH

REMARKS: 1 SET COMPLETE

LOCATION: SECOND FLOOR BREAKOUT ROOMS FROM

NOTE: VERIFY DOOR SWING DIRECTION ON PLAN

(B) STEEL DOOR WITH BOTTOM LOUVER
 SPECIFICATIONS: SHALL BE 1.5M THICK GAUGE 18 BARE METAL THICKNESS 4MM THICK POWDER-COATED FINISH, COLORED ROLLED STEEL SHEET WITH 1.5MM THICK GA. IS 4.5MM X 1.5MM X 2 PLYS OF POLYURETHANE INSULATION ON BASE METAL WITH HONEYCOMB CORE INSULATION FINISHING SHALL BE FULLY WELDED, LEAK TIGHT GAUGE IS 4.5MM X 1.5MM SINGLE RIBBON YELLOW METAL FRAMES OF THE SAME GAUGE SHALL BE WELDED TO THE FRAME WITH HARDWARE AND ACCESSORIES FROM FINISH SHALL POWDER-COATED FINISH REFERENCE COLOR IS REFERENCE POWDER COAT "CONCRETE" 5-YEAR WEAR COMPLETE WALL SPACING MODULAR TO FINISH

REMARKS: 1 SET COMPLETE

LOCATION: FEMALE TOILET X

NOTE: VERIFY DOOR SWING DIRECTION ON PLAN

(C) SCHEDULE OF DOORS
 SCALE: 1:50M

NO.	DESCRIPTION	LOCATION
1	STEEL DOOR	SECOND FLOOR BREAKOUT ROOMS FROM
2	STEEL DOOR WITH BOTTOM LOUVER	FEMALE TOILET X

(D) ADDITIONAL STEEL DOOR
 SPECIFICATIONS: SHALL BE 1.5M THICK GAUGE 18 BARE METAL THICKNESS 4MM THICK POWDER-COATED FINISH, COLORED ROLLED STEEL SHEET WITH 2 PLYS OF POLYURETHANE INSULATION ON BASE METAL WITH HONEYCOMB CORE INSULATION FINISHING SHALL BE FULLY WELDED, LEAK TIGHT GAUGE IS 4.5MM X 1.5MM SINGLE RIBBON YELLOW METAL FRAMES OF THE SAME GAUGE SHALL BE WELDED TO THE FRAME WITH HARDWARE AND ACCESSORIES FROM FINISH SHALL POWDER-COATED FINISH REFERENCE COLOR IS REFERENCE POWDER COAT "CONCRETE" 5-YEAR WEAR COMPLETE WALL SPACING MODULAR TO FINISH

REMARKS: 1 SET COMPLETE

LOCATION: BREAK-OUT ROOMS

NOTE: VERIFY DOOR SWING DIRECTION ON PLAN

PRINCIPAL ARCHITECT:	PROJECT TITLE:	OWNER:	ENDORSED BY:	RECOMMENDING APPROVAL:	APPROVED:	SHEET CONTENTS:	SHEET NO.:
AE MAIN ARCHITECTS INC.	COMPLETION OF THE LOBBY AREA AND BREAKOUT ROOMS OF THE UPOLI INTERNATIONAL CONVENTION CENTER	UNIVERSITY OF THE PHILIPPINES OPEN UNIVERSITY (UPOU)	<i>[Signature]</i> DR. MARCEL B. SANDO PROJECT MANAGER / CHIEF ARCHITECT	<i>[Signature]</i> DR. ZAFAR S. SALGADUE ARCHITECT	<i>[Signature]</i> DR. MARCEL B. SANDO PROJECT MANAGER / CHIEF ARCHITECT	BREAK-OUT ROOMS AND INSTALLATION OF DOORS	A1-6

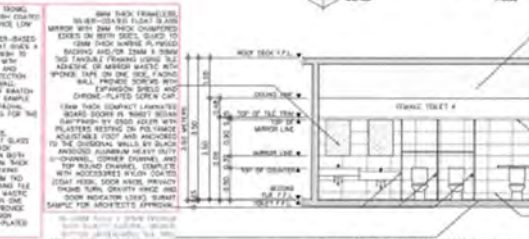
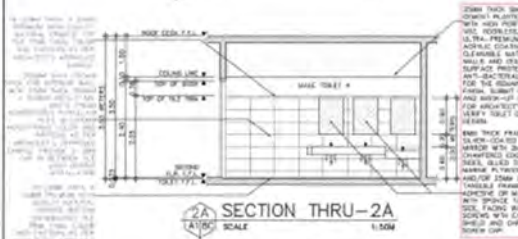
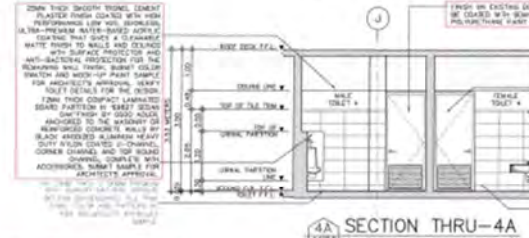
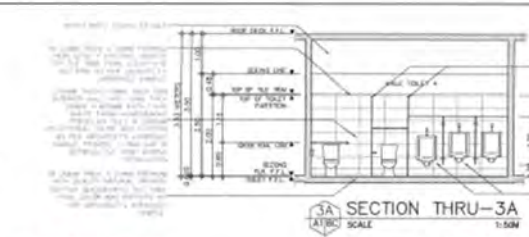
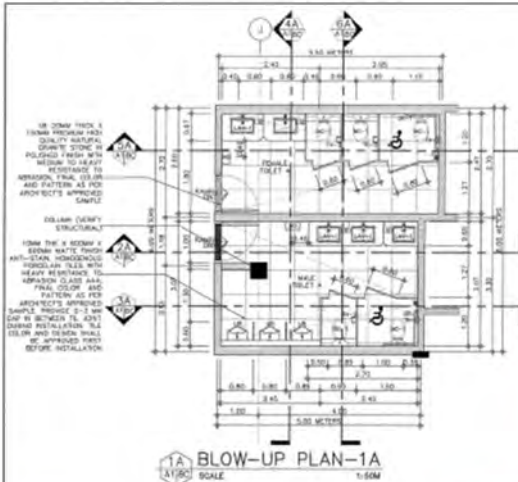

SPECIFICATIONS:

1. WALL FINISH SHALL BE COMPACT LAMINATED BOARD FINISH IN WHITE BEIGE. BOARD FINISH TO BE MATCHED WITH PLASTER FINISH. BOARD TO BE FINISHED WITH PLASTER FINISH. BOARD TO BE FINISHED WITH PLASTER FINISH.

2. FLOOR FINISH SHALL BE 20MM THICK 8' FINISH PROGRAM FROM QUALITY MANUFACTURER. GRANITE STONE IN FLOORING FINISH WITH REFLECTIVE TO ANGLE OF REFLECTION, FINAL COLOR AND PATTERN AS PER ARCHITECT'S APPROVED SAMPLE.

3. ISOLATE GIBBY STRUCTURAL.

4. USE THE 8' SYSTEM 8' SYSTEM WHITE GIBBY ANTI-STAIN, HOMOGENEOUS FLOORING TILES WITH HEAVY REINFORCING TO MATCH COLOR AND PATTERN AS PER ARCHITECT'S APPROVED SAMPLE. FINISH TO 1/2" MIN GAP IN BETWEEN TILE AND TRIMMING REGISTRATION. TILE SETTING MUST BE APPROVED FIRST BEFORE INSTALLATION.

1. WALL FINISH SHALL BE COMPACT LAMINATED BOARD FINISH IN WHITE BEIGE. BOARD FINISH TO BE MATCHED WITH PLASTER FINISH. BOARD TO BE FINISHED WITH PLASTER FINISH. BOARD TO BE FINISHED WITH PLASTER FINISH.

2. FLOOR FINISH SHALL BE 20MM THICK 8' FINISH PROGRAM FROM QUALITY MANUFACTURER. GRANITE STONE IN FLOORING FINISH WITH REFLECTIVE TO ANGLE OF REFLECTION, FINAL COLOR AND PATTERN AS PER ARCHITECT'S APPROVED SAMPLE.

3. ISOLATE GIBBY STRUCTURAL.

4. USE THE 8' SYSTEM 8' SYSTEM WHITE GIBBY ANTI-STAIN, HOMOGENEOUS FLOORING TILES WITH HEAVY REINFORCING TO MATCH COLOR AND PATTERN AS PER ARCHITECT'S APPROVED SAMPLE. FINISH TO 1/2" MIN GAP IN BETWEEN TILE AND TRIMMING REGISTRATION. TILE SETTING MUST BE APPROVED FIRST BEFORE INSTALLATION.

1. WALL FINISH SHALL BE COMPACT LAMINATED BOARD FINISH IN WHITE BEIGE. BOARD FINISH TO BE MATCHED WITH PLASTER FINISH. BOARD TO BE FINISHED WITH PLASTER FINISH. BOARD TO BE FINISHED WITH PLASTER FINISH.

2. FLOOR FINISH SHALL BE 20MM THICK 8' FINISH PROGRAM FROM QUALITY MANUFACTURER. GRANITE STONE IN FLOORING FINISH WITH REFLECTIVE TO ANGLE OF REFLECTION, FINAL COLOR AND PATTERN AS PER ARCHITECT'S APPROVED SAMPLE.

3. ISOLATE GIBBY STRUCTURAL.

4. USE THE 8' SYSTEM 8' SYSTEM WHITE GIBBY ANTI-STAIN, HOMOGENEOUS FLOORING TILES WITH HEAVY REINFORCING TO MATCH COLOR AND PATTERN AS PER ARCHITECT'S APPROVED SAMPLE. FINISH TO 1/2" MIN GAP IN BETWEEN TILE AND TRIMMING REGISTRATION. TILE SETTING MUST BE APPROVED FIRST BEFORE INSTALLATION.

LEVEL	DESCRIPTION	QUANTITY	UNIT
L1-1	UNDER THE GIBBY LAMINATE	800	SQ. M
L1-2	GIBBY LAMINATE	800	SQ. M
L1-3	WALL FINISH LAMINATE	800	SQ. M
L1-4	WALL FINISH LAMINATE	800	SQ. M
L1-5	WALL FINISH LAMINATE	800	SQ. M
L1-6	WALL FINISH LAMINATE	800	SQ. M
L1-7	WALL FINISH LAMINATE	800	SQ. M
L1-8	WALL FINISH LAMINATE	800	SQ. M
L1-9	WALL FINISH LAMINATE	800	SQ. M
L1-10	WALL FINISH LAMINATE	800	SQ. M
L1-11	WALL FINISH LAMINATE	800	SQ. M
L1-12	WALL FINISH LAMINATE	800	SQ. M
L1-13	WALL FINISH LAMINATE	800	SQ. M
L1-14	WALL FINISH LAMINATE	800	SQ. M
L1-15	WALL FINISH LAMINATE	800	SQ. M
L1-16	WALL FINISH LAMINATE	800	SQ. M
L1-17	WALL FINISH LAMINATE	800	SQ. M
L1-18	WALL FINISH LAMINATE	800	SQ. M
L1-19	WALL FINISH LAMINATE	800	SQ. M
L1-20	WALL FINISH LAMINATE	800	SQ. M
L1-21	WALL FINISH LAMINATE	800	SQ. M
L1-22	WALL FINISH LAMINATE	800	SQ. M
L1-23	WALL FINISH LAMINATE	800	SQ. M
L1-24	WALL FINISH LAMINATE	800	SQ. M
L1-25	WALL FINISH LAMINATE	800	SQ. M
L1-26	WALL FINISH LAMINATE	800	SQ. M
L1-27	WALL FINISH LAMINATE	800	SQ. M
L1-28	WALL FINISH LAMINATE	800	SQ. M
L1-29	WALL FINISH LAMINATE	800	SQ. M
L1-30	WALL FINISH LAMINATE	800	SQ. M
L1-31	WALL FINISH LAMINATE	800	SQ. M
L1-32	WALL FINISH LAMINATE	800	SQ. M
L1-33	WALL FINISH LAMINATE	800	SQ. M
L1-34	WALL FINISH LAMINATE	800	SQ. M
L1-35	WALL FINISH LAMINATE	800	SQ. M
L1-36	WALL FINISH LAMINATE	800	SQ. M
L1-37	WALL FINISH LAMINATE	800	SQ. M
L1-38	WALL FINISH LAMINATE	800	SQ. M
L1-39	WALL FINISH LAMINATE	800	SQ. M
L1-40	WALL FINISH LAMINATE	800	SQ. M
L1-41	WALL FINISH LAMINATE	800	SQ. M
L1-42	WALL FINISH LAMINATE	800	SQ. M
L1-43	WALL FINISH LAMINATE	800	SQ. M
L1-44	WALL FINISH LAMINATE	800	SQ. M
L1-45	WALL FINISH LAMINATE	800	SQ. M
L1-46	WALL FINISH LAMINATE	800	SQ. M
L1-47	WALL FINISH LAMINATE	800	SQ. M
L1-48	WALL FINISH LAMINATE	800	SQ. M
L1-49	WALL FINISH LAMINATE	800	SQ. M
L1-50	WALL FINISH LAMINATE	800	SQ. M

SECOND FLOOR PUBLIC MALE & FEMALE TOILET

AT SHOWS

PROJECT TITLE: COMPLETION OF THE LOBBY AREA AND BREAKOUT ROOMS OF THE UPOU INTERNATIONAL CONVENTION CENTER

CLIENT: UNIVERSITY OF THE PHILIPPINES OPEN UNIVERSITY (UPOU)

DESIGNED BY: [Signature]

CHECKED BY: [Signature]

RECOMMENDING APPROVAL: [Signature]

APPROVED: [Signature]

DATE: 10/20/2023

LOCATION: UPOU CAMPUS SAN RAMON, SAN RAMON, BULACAN

PROJECT NO.: 2023-001

DATE: 10/20/2023

SCALE: AS SHOWN

SHEET NO.: A1-8C

Section VIII. Bill of Quantities

DETAILED CONSTRUCTION ESTIMATE WORKSHEET (DCEW)

Project :	COMPLETION OF THE LOBBY AREA AND BREAKOUT ROOMS OF THE UPOU INTERNATIONAL CONVENTION CENTER	Prepared / Estimated by:		Submitted by:	Date:
Location :	UPOU Headquarters, Maahas, Los Baños, Laguna	Certified Correct:		Name w/ Signature & Designation	
Subject :	BILL OF MATERIALS AND COST ESTIMATES (DETAILED CONSTRUCTION ESTIMATE WORKSHEET)			Address of Bidder:	
				Estimated Project Cost:	0.00
				Name & Signature of General Manager	
				No. of Days to Complete:	45 CALENDAR DAYS

ITEM NO.	ITEM OF WORK	UNIT	QTY.	DIRECT COST				SUB-TOTAL DIRECT COST	UNIT COST (PHP)
				MATERIALS		LABOR			
				PER UNIT	MAT'L COST	PER UNIT	LABOR COST		
I.	GENERAL REQUIREMENTS								
A.	Construction Aid								
	1. Temporary Office, Sheds, Storage, Barricades etc.	lot	1.00		0.00		0.00	0.00	0.00
	2. Temporary Power and Water Supply	lot	1.00		0.00	-	-	0.00	0.00
	3. Health and Safety expenses, PPE, etc.	lot	1.00		0.00	-	-	0.00	0.00
	4. Tools and equipment including scaffoldings (rental only)	lot	1.00	-	-		0.00	0.00	0.00
II.	MASONRY								
A.	Repair/Replastering of wall plastering defects: 25mm thick smooth trowel cement plaster finish, bonded to the existing CHB wall/substrate using a styrene-acrylic admixture product, coated with plain finish semi-gloss high performance low voc, odorless, ultra-premium, water-based acrylic coating that gives a cleanable matte finish to walls and ceilings with surface protector and anti-bacterial protection. Provide high-performance acrylic skimcoat to interior wall to achieve an even and smooth concrete surface before applying paint primer.	lor	1.00		0.00		0.00	0.00	0.00
III.	METALS								
A.	Main Staircase Railing, Viewing Balcony Railing: Shall be 42mm outside diameter, Grade 304, Stainless Steel Tubular Handrail in hairline finish with 10mm x 40mm flat bar vertical balustrade, fully doweled to concrete zocalo at every 1950mm, coated with high performance two component solvent-based epoxy enamel paint finish; with 10mm x 40mm flat bar horizontal support balustrade, coated with high performance two component solvent-based epoxy enamel paint finish.	lm	78.02		0.00		0.00	0.00	0.00

ITEM NO.	ITEM OF WORK	UNIT	QTY.	DIRECT COST				SUB-TOTAL DIRECT COST	UNIT COST (PHP)
				MATERIALS		LABOR			
				PER UNIT	MATL. COST	PER UNIT	LABOR COST		
1.	Dismantling of existing tubular handrails and installation of new 42mm outside diameter, Grade 304, Stainless Steel Tubular Handrail in hairline finish	m	10.00		0.00		0.00	0.00	
2.	Existing 10mm x 40mm flat bar vertical balustrade shall be applied with rust remover and rust converter and shall be coated with high performance two component solvent-based epoxy enamel paint finish; with 10mm x 40mm flat bar horizontal support balustrade, coated with high performance two component solvent-based epoxy enamel paint finish.	sq.m.	12.95		0.00		0.00	0.00	
IV. DOORS									
A.	Complete Supply and Installation of Doors & Jambs complete with door knobs/locksets, handles, hinges, patch fittings, U-Channel Hinges & accessories as per Plan, Drawing Details and Specifications								
1.	D-10a 1000mm x 2400mm x 44mm thick, 1.3mm thick, gauge 18 base metal thickness, 45mm thick, cold rolled steel door, made of chromate-free electro galvanized steel sheet with zinc coating layer applied on base metal with honeycomb core insulation. Framing shall be fully welded, 1.6mm thick, gauge 16 x 45mm x 140mm single rabbet, hollow metal frames of the same door panel material. Complete with accessories; door finish shall be in powder-coated finish. Complete wall opening masonry to finish. (Loc: Chairs & Tables Storage Rm 3)	set	1.00		0.00		0.00	0.00	
2.	D-14b 900mm x 2400mm, 1.3mm thick, gauge 18 base metal thickness, 45mm thk, powder coated finish, cold rolled steel door with 1.2mm thick gauge 18 x 45mm x 75mm Z profile bottom louver blades, made of chromate-free electro galvanized steel sheet with zinc coating layer applied on base metal and honeycomb core insulation. Framing shall be fully welded, 1.6mm thick, gauge 16 x 45mm x 140mm single rabbet, hollow metal frames of the same door panel material. Complete with accessories. Door finish shall be coated with semi-gloss polyurethane paint finish. Complete wall opening masonry to finish. (Loc: Female Toilet 4)	set	1.00		0.00		0.00	0.00	
3.	D-17b 2000mm x 2400mm x 1.6mm thick gauge 16 base metal thickness, 45mm thick, cold rolled steel door, made of chromate-free electro galvanized steel sheet with zinc coating layer applied on base metal and filled in with sound absorbing material (fiberglass/rockwool on honeycomb insulation) with perimeter seal. Framing shall be fully welded, 1.6mm thick, gauge 16 x 45mm x 140mm single rabbet, hollow metal frames of the same door panel material. Complete with jamb and head seal, threshold, automatic door bottom, meeting stile seal and accessories in stainless steel grade 304, hairline finish (no. 4 finish). Door finish shall be in powder-coated finish. Complete wall opening masonry to finish. (Loc: Breakout Rooms 1, 2, 3 & 4)	sets	4.00		0.00		0.00	0.00	

ITEM NO.	ITEM OF WORK	UNIT	QTY.	DIRECT COST				SUB-TOTAL DIRECT COST	UNIT COST (PHP)
				MATERIALS		LABOR			
				PER UNIT	MATL. COST	PER UNIT	LABOR COST		
B. Builder's Hardware (for new and installed Doors)									
1.	Manual Flush Bolt for Steel Doors - brass faceplate with steel component. Bolt shall be set on inactive door of a pair with 25mm x 172mm face plate and 13mm standard threaded rod size in satin chrome finish (US26D) with 3 hour fire rating for metal doors complying to ANSI 156.16 for L14251	pcs	8.00		0.00		0.00	0.00	0.00
2.	One-Way Deadbolt Lock (For: D-10a and D-14b)	pcs	6.00		0.00		0.00	0.00	0.00
3.	Vertical Pull Handle for Acoustical Steel Door (For: D-17b)	pcs	16.00		0.00		0.00	0.00	0.00
4.	Locksets								
4.1.	Lever Type Lockset (wood & steel doors) (For: D-10a and D-14b)	pcs	6.00		0.00		0.00	0.00	0.00
5.	Concealed Door Closer	pcs	14.00		0.00		0.00	0.00	0.00
6.	Door Stop 1 (steel doors/wood doors)	pcs	14.00		0.00		0.00	0.00	0.00
7.	Door Coordinator (UL Listed) (For: D-17b)	pcs	4.00		0.00		0.00	0.00	0.00
IV. DOORS									
A. Complete Supply and Installation of Ceiling Finishes as per Plan, Drawing Details and Specifications									
1.	CF-3 Existing plasterboard/gypsum board shall be coated with high performance low VOC, odorless, ultra-premium water-based acrylic coating that gives a cleanable matte finish to walls and ceilings with surface protector and anti-bacterial protection.	sq.m.	809.01		0.00		0.00	0.00	0.00

ITEM NO.	ITEM OF WORK	UNIT	QTY.	DIRECT COST				SUB-TOTAL DIRECT COST	UNIT COST (PHP)
				MATERIALS		LABOR			
				PER UNIT	MATL. COST	PER UNIT	LABOR COST		
B. Complete Supply and Installation of Floor Finishes as per Plan, Drawing Details and Specifications									
1.	FF-4 10mm thk x 600mm x 600mm double polished finish anti-stain, homogenous porcelain tiles with heavy resistance to abrasion class AAA (Loc.: Lobby and Breakout Rooms 1, 2, 3, & 4)	sq.m.	763.15		0.00		0.00	0.00	0.00
2.	FF-8 Main stairs flooring: Natural Granite Stone finish and nosing. Shall be 18-20mm thick premium high-quality natural granite stone in polished finish with medium to heavy resistance to abrasion, provide 18-20mm thick x 50mm premium high-quality honed finish granite nosing with medium to heavy resistance to abrasion. Tile color and pattern as per architect's approved sample.	sq.m.	86.94		0.00		0.00	0.00	0.00
3.	FF-10 Storage Room Flooring: Plain cement plaster floor finish with epoxy paint. Shall be plain cement smooth steel trowel finish with concrete hardener coated with a high performance, two component water-based acrylic epoxy paint which has a superior chemical, solvent and stain resistance, odorless and UV resistant finish. It has the further excellent of brushability and easy water clean-up. Submit color swatches of paints for architect's approval. Verify structural drawings for slab thickness.	sq.m.	20.00		0.00		0.00	0.00	0.00
4.	FF-13 Natural Granite stone nosing 2: Interior Floor Termination, shall be 18-20mm thick x 50mm/100mm premium high quality natural granite stone in polished finish with medium to heavy resistance to abrasion. Tile color and pattern as per architect's approved sample.	sq.m.	0.80		0.00		0.00	0.00	0.00
5.	FF-14 Natural Granite stone nosing 3: Interior Floor Termination, shall be 18-20mm thick x 150mm premium high quality natural granite stone in polished finish with medium to heavy resistance to abrasion. Final color and pattern as per architect's approved sample.	sq.m.	0.40		0.00		0.00	0.00	0.00
C. Complete Supply and Installation of Wall Finishes complete up to plastering and painting works if needed as per Plan, Drawing Details and Specifications									
1.	WF-2a Existing Interior CHB Walls and Columns shall be coated with high performance low voc, odorless, ultra-premium water-based acrylic coating that gives a cleanable matte finish to walls and ceilings with surface protector and anti-bacterial protection	sq.m.	810.14		0.00		0.00	0.00	0.00

ITEM NO.	ITEM OF WORK	UNIT	QTY.	DIRECT COST				SUB-TOTAL DIRECT COST	UNIT COST (PHP)
				MATERIALS		LABOR			
				PER UNIT	MAT'L. COST	PER UNIT	LABOR COST		
	WF-2b Dry Wall Partition Painted Finish. 12mm thick square edge, sag resistant regular gypsum board with ivory face paper, shall be coated with high performance low VOC, odorless, ultra-premium water-based acrylic coating that gives a cleanable matte finish to walls and ceilings with surface protector and anti-bacterial protection.								
2.	Replacement of rusted framing. Framing shall be 0.60mm thick gauge 24 x 35mm x 76mm galvanized light steel top and bottom tracks and 0.60mm gauge 24 x 35mm x 76mm vertical and horizontal studs spaced at 600mm both ways, complete with screws, accessories and 0.40mm gauge 26 x 25mm x 25mm corner bead with BPS (Bureau of Product Standards) certification. (Location: Breakout Rooms 1, 3, and 4)	sq.m.	84.00		0.00		0.00	0.00	0.00
3.	Existing remaining upper CHB wall shall be: 25mm thick smooth trowel cement plaster finish coated with high performance low voc, odorless, ultra-premium water-based acrylic coating that gives a cleanable matte finish to walls and ceilings with surface protector and anti-bacterial protection for the remaining wall finish. (Location: Public Toilets)	sq.m.	57.36		0.00		0.00	0.00	0.00
4.	WF-2d Dry Wall Partition (temporary). Shall be 9mm thick standard plasterboard on 0.60mm thick gauge 26 x 35mm x 76mm galvanized light steel top and bottom tracks, set in place with construction adhesive and 0.40mm gauge 26 x 35mm x 76mm vertical and horizontal studs spaced at 1000mm both ways, complete with screws, accessories, coated with high performance low voc, odorless, ultra-premium water-based acrylic coating that gives a cleanable matte finish to walls and ceilings with surface protector and anti-bacterial protection. Submit color swatch and mock-up paint sample for architect's approval.	sq.m.	56.80		0.00		0.00	0.00	0.00
D.	Complete Repainting of Existing Toilet Doors								
	Door finish shall be coated with semi-gloss polyurethane paint finish. Submit color swatch and mock-up paint sample for architects' approval.	sq.m.	12.96		0.00		0.00	0.00	0.00
V. SPECIALTIES									
A. Complete Supply and Installation of Compartments and Cubicle as per Plan, Drawing Details and Specifications									
1. Toilet Cubicle Door with Partition									
	1.1 3300mm x 1200mm x 1800mm; 3 partitions & 3 doors	sets	2.00		0.00		0.00	0.00	0.00
	1.2 2400mm x 1200mm x 1800mm; 2 partitions & 2 doors	sets	2.00		0.00		0.00	0.00	0.00
2. Urinal Partitions									
	2.1 400mm x 1200mm x 12mm thk urinal partition	sets	5.00		0.00		0.00	0.00	0.00
3. Toilet Cubicle Ledge									
	3.1 Toilet Cubicle Ledge 0.20m x 0.90m	sets	6.00		0.00		0.00	0.00	0.00
	3.2 Toilet Cubicle Ledge 0.20m x 1.50m	sets	4.00		0.00		0.00	0.00	0.00
4. Tissue Paper Holder									

ITEM NO.	ITEM OF WORK	UNIT	QTY.	DIRECT COST				SUB-TOTAL DIRECT COST	UNIT COST (PHP)
				MATERIALS		LABOR			
				PER UNIT	MATL. COST	PER UNIT	LABOR COST		
4.1	Tissue Paper Holder 1: shall be white vitreous china, semi-recessed wall-mounted tissue paper holder	sets	8.00		0.00		0.00	0.00	
4.2	Tissue Paper Holder 2: shall be anchored to partition wall, shall be black PV nylon-coated, wall-mounted tissue paper holder with lid cover and concealed screws.	sets	17.00		0.00		0.00	0.00	
5.	Liquid Soap Dispenser								
	shall be 155mm x 100mm x 73mm manual push type, stainless steel liquid soap dispenser in satin finish with 800ml liquid content.	sets	18.00		0.00		0.00	0.00	
B.	Mirrors								
	Facial @ Mirror Male and Female Toilets - 6mm thick frameless, silver-coated float glass mirror with 2mm thick chamfered edges on both sides, glued to 12mm thick marine plywood backing and/or 25mm x 50mm TKD Tangle framing using tile adhesive or mirror mastic with sponge tape on one side, facing wall. Provide screws with expansion shield and chrome-plated screw cap								
1.	600mm x 900mm x 6mm thk frameless silver-coated float glass	sets	10.00		0.00		0.00	0.00	
INITIAL GRAND TOTAL					0.00		0.00	0.00	

SUMMARY OF BREAKDOWN OF TOTAL LUMPSUM BID PRICE

Project : COMPLETION OF THE LOBBY AREA AND BREAKOUT ROOMS OF THE UPOU INTERNATIONAL CONVENTION CENTER

A. ESTIMATED DIRECT COST				
A.1.	Materials and Equipment Cost (exclusive of VAT)	P	0.00	
A.2.	Labor Cost and Equipment Rental (exclusive of VAT)	P	0.00	
SUB - TOTAL (EDC)				0.00
A.3.	Mobilization and Demobilization (1 % of EDC)	P		0.00
TOTAL A			P	0.00
B. INDIRECT COST				
B.1. Mark-up				
B.1.1.	Overhead expenses, unforeseen contingencies miscellaneous expenses [(A) * OCM%]	P		
B.1.2.	Contractor's profit [(A) * P%]	P		
SUB-TOTAL (B.1.)			P	0.00
B.2. Taxes				
B.2.1.	12% VAT of [(A) + (B.1)]	P	0.00	
B.2.2.	Municipal Tax (per Municipal Tax of Los Baños)	P		
SUB-TOTAL (B.2.)			P	0.00
TOTAL B			P	0.00
TOTAL APPROVED BUDGET FOR CONSTRUCTION			P	0.00
(Amount in words)				

Submitted by:

(Name of Bidder)

(Date)

Legend:

-should be filled-up

Section IX. Checklist of Technical and Financial Documents

I. TECHNICAL COMPONENT ENVELOPE

Class “A” Documents

Legal Documents

- (a) Valid PhilGEPS Registration Certificate (Platinum Membership) (all pages) in accordance with Section 8.5.2 of the IRR;

Technical Documents

- (b) Statement of the prospective bidder of all its ongoing government and private contracts, including contracts awarded but not yet started, if any, whether similar or not similar in nature and complexity to the contract to be bid (UPOU BAC Form No. 1); **and**
- (c) Statement of the bidder’s Single Largest Completed Contract (SLCC) similar to the contract to be bid, except under conditions provided under the rules. The SLCC should be at least 50% of the ABC. (UPOU BAC Form No. 2);
“The prospective bidder must have completed an SLCC that is similar to the contract to be bid, and whose value, adjusted to current prices using the PSA consumer price indices, must be at least fifty (50%) of the ABC to be bid: *Provided however,* That contractors under Small A and Small B categories without similar experience on the contract to be bid may be allowed to bid if the cost of such contract is not more than the Allowable Range of Contract Cost (ARCC) of their registration based on the guidelines as prescribed by the PCAB.”**and**
- (d) Special PCAB License in case of Joint Ventures;
and registration for the type and cost of the contract to be bid; **and**
- (e) Original copy of Bid Security. If in the form of a Surety Bond, submit also a certification issued by the Insurance Commission;**or**
Original copy of Notarized Bid Securing Declaration (UPOU BAC Form No. 3); **and**
- (f) Project Requirements, which shall include the following:
 - a. Organizational chart for the contract to be bid;
 - b. Key personnel Letter Certificate to UPOU to be assigned to the contract to be bid, with their complete qualification (Bio-Data) and experience data (COE):

<u>Key Personnel</u>	<u>General Experience</u>
1. Project Architect/Civil Engineer (with valid license)	Min. 5 yrs
2. Safety Officer/Engineer	Min. 5 yrs w/ COSH Certificate
3. General Foreman	Min. 5 yrs

Notes: Personnel with multiple expertise and qualifications with at most two different positions mentioned above are allowed as long as he/she can provide the necessary documentation in support of his/her qualifications such as appropriate valid licenses, certificate of training, accreditation, and the like should be submitted separately for each position.

- c. List of contractor's major equipment units, which are owned, leased, and/or under purchase agreements, supported by proof of ownership or certification of availability of equipment from the equipment lessor/vendor for the duration of the project, as the case may be; **and**

A. Equipment	No. of Units
1. Grinder	Min. 2 units
2. Tile Cutter	Min. 2 units
3. Welding Machine	Min. 2 units
4. Compressor	Min. 1 unit
B. Others	No. of Units
1. PPE (Personal Protective Equipment) (includes hard hat, safety vest, safety shoes, safety harness, safety gloves)	Min. of 15pcs per item except safety harness (5pcs only)

- (g) Original duly signed Omnibus Sworn Statement (OSS) (UPOU BAC Form No. 4);
and if applicable, Original Notarized Secretary's Certificate (UPOU BAC Form No. 5) in case of a corporation, partnership, or cooperative; or Original Special Power of Attorney (UPOU BAC Form No. 6) of all members of the joint venture giving full power and authority to its officer to sign the OSS and do acts to represent the Bidder.

Financial Documents

- (h) The prospective bidder's computation of Net Financial Contracting Capacity (NFCC) (UPOU BAC Form No. 7).

Class "B" Documents

- (i) If applicable, duly signed joint venture agreement (JVA) in accordance with RA No. 4566 and its IRR in case the joint venture is already in existence (UPOU BAC Form No. 8). **or**
 duly notarized statements from all the potential joint venture partners stating that they will enter into and abide by the provisions of the JVA in the instance that the bid is successful.

- (j) Affidavit of Site Inspection

II. FINANCIAL COMPONENT ENVELOPE

- (k) Original of duly signed and accomplished Bid Form (UPOU BAC Form No. 9);
and

Other documentary requirements under RA No. 9184

- (l) Duly signed Detailed Construction Estimates Worksheet (DCEW); **and**
 (m) Duly signed Summary of Breakdown of Total Lump Sum Bid Prices; **and**
 (n) Cash Flow by Quarter and Payments Schedule.

Notes:

The prescribed documents in the checklist are mandatory to be submitted in the Bid.

STATEMENT OF ALL ONGOING GOVERNMENT & PRIVATE CONTRACTS INCLUDING CONTRACTS AWARDED BUT NOT YET STARTED

Business Name : _____

Business Address : _____

Name of Contract	Date of Contract	Duration of Contract	a. Owner's Name b. Address c. Telephone Nos.	Nature of Work	Contractor's Role		a. Total Contract Value at Award b. Total Contract Value at Completion c. Date of Completion	% of Accomplishment		Value of Outstanding Works
					Description	%		Planned	Actual	
<u>Government</u>										
<u>Private</u>										
Total Cost										

- Note: This statement shall be supported with:
1. Project Owner's Certificate of Final Acceptance issued by the Owner other than the Contractor or the Constructors Performance Evaluation System (CPES) Final Rating, which must be at least satisfactory.
 2. Notice of Award and/or Notice to Proceed

Submitted by : _____
(Printed Name & Signature)

Designation : _____

Date : _____

STATEMENT OF BIDDER'S SINGLE LARGEST COMPLETED CONTRACT (SLCC) SIMILAR TO THE CONTRACT TO BE BID

Business Name : _____

Business Address : _____

Name of Contract	Date of Contract	Duration of Contract	a. Owner's Name b. Address c. Telephone Nos.	Nature of Work	Contractor's Role		a. Total Contract Value at Award b. Total Contract Value at Completion c. Date of Completion	% of Accomplishment		Value of Outstanding Works
					Description	%		Planned	Actual	
<u>Government</u>										
<u>Private</u>										
									Total Cost	

Note: This statement shall be supported with:

1. Project Owner's Certificate of Final Acceptance issued by the Owner other than the Contractor or the Constructors Performance Evaluation System (CPES) Final Rating, which must be at least satisfactory.
2. Notice of Award and/or Notice to Proceed

Submitted by : _____
(Printed Name & Signature)

Designation : _____

Date : _____

Bid Securing Declaration Form

REPUBLIC OF THE PHILIPPINES)
CITY OF _____) S.S.

BID SECURING DECLARATION **Project Identification: IB No. 25-01-001**

To: *[Insert name and address of the Procuring Entity]*

I/We, the undersigned, declare that:

1. I/We understand that, according to your conditions, bids must be supported by a Bid Security, which may be in the form of a Bid Securing Declaration.
2. I/We accept that: (a) I/we will be automatically disqualified from bidding for any procurement contract with any procuring entity for a period of two (2) years upon receipt of your Blacklisting Order; and, (b) I/we will pay the applicable fine provided under Section 6 of the Guidelines on the Use of Bid Securing Declaration, within fifteen (15) days from receipt of the written demand by the procuring entity for the commission of acts resulting to the enforcement of the bid securing declaration under Sections 23.1(b), 34.2, 40.1 and 69.1, except 69.1(f), of the IRR of RA No. 9184; without prejudice to other legal action the government may undertake.
3. I/We understand that this Bid Securing Declaration shall cease to be valid on the following circumstances:
 - a. Upon expiration of the bid validity period, or any extension thereof pursuant to your request;
 - b. I am/we are declared ineligible or post-disqualified upon receipt of your notice to such effect, and (i) I/we failed to timely file a request for reconsideration or (ii) I/we filed a waiver to avail of said right; and
 - c. I am/we are declared the bidder with the Lowest Calculated Responsive Bid, and I/we have furnished the performance security and signed the Contract.

IN WITNESS WHEREOF, I/We have hereunto set my/our hand/s this ____ day of *[month]* *[year]* at *[place of execution]*.

[Insert NAME OF BIDDER OR ITS AUTHORIZED REPRESENTATIVE]

[Insert signatory's legal capacity]

Affiant

[Jurat]

[Format shall be based on the latest Rules on Notarial Practice]

Omnibus Sworn Statement (Revised)

REPUBLIC OF THE PHILIPPINES)
CITY/MUNICIPALITY OF _____) S.S.

AFFIDAVIT

I, [Name of Affiant], of legal age, [Civil Status], [Nationality], and residing at [Address of Affiant], after having been duly sworn in accordance with law, do hereby depose and state that:

1. *[Select one, delete the other:]*

[If a sole proprietorship:] I am the sole proprietor or authorized representative of [Name of Bidder] with office address at [address of Bidder];

[If a partnership, corporation, cooperative, or joint venture:] I am the duly authorized and designated representative of [Name of Bidder] with office address at [address of Bidder];

2. *[Select one, delete the other:]*

[If a sole proprietorship:] As the owner and sole proprietor, or authorized representative of [Name of Bidder], I have full power and authority to do, execute and perform any and all acts necessary to participate, submit the bid, and to sign and execute the ensuing contract for [Name of the Project] of the [Name of the Procuring Entity], as shown in the attached duly notarized Special Power of Attorney;

[If a partnership, corporation, cooperative, or joint venture:] I am granted full power and authority to do, execute and perform any and all acts necessary to participate, submit the bid, and to sign and execute the ensuing contract for [Name of the Project] of the [Name of the Procuring Entity], as shown in the attached [state title of attached document showing proof of authorization (e.g., duly notarized Secretary's Certificate, Board/Partnership Resolution, or Special Power of Attorney, whichever is applicable)];

3. [Name of Bidder] is not "blacklisted" or barred from bidding by the Government of the Philippines or any of its agencies, offices, corporations, or Local Government Units, foreign government/foreign or international financing institution whose blacklisting rules have been recognized by the Government Procurement Policy Board, by itself or by relation, membership, association, affiliation, or controlling interest with another blacklisted person or entity as defined and provided for in the Uniform Guidelines on Blacklisting;
4. Each of the documents submitted in satisfaction of the bidding requirements is an authentic copy of the original, complete, and all statements and information provided therein are true and correct;
5. [Name of Bidder] is authorizing the Head of the Procuring Entity or its duly authorized representative(s) to verify all the documents submitted;

6. *[Select one, delete the rest:]*

[If a sole proprietorship:] The owner or sole proprietor is not related to the Head of the Procuring Entity, members of the Bids and Awards Committee (BAC), the Technical Working Group, and the BAC Secretariat, the head of the Project Management Office or the end-user unit, and the project consultants by consanguinity or affinity up to the third civil degree; *[If a partnership or cooperative:]* None of the officers and members of *[Name of Bidder]* is related to the Head of the Procuring Entity, members of the Bids and Awards Committee (BAC), the Technical Working Group, and the BAC Secretariat, the head of the Project Management Office or the end-user unit, and the project consultants by consanguinity or affinity up to the third civil degree;

[If a corporation or joint venture:] None of the officers, directors, and controlling stockholders of *[Name of Bidder]* is related to the Head of the Procuring Entity, members of the Bids and Awards Committee (BAC), the Technical Working Group, and the BAC Secretariat, the head of the Project Management Office or the end-user unit, and the project consultants by consanguinity or affinity up to the third civil degree;

7. *[Name of Bidder]* complies with existing labor laws and standards; and

8. *[Name of Bidder]* is aware of and has undertaken the responsibilities as a Bidder in compliance with the Philippine Bidding Documents, which includes:

- a. Carefully examining all of the Bidding Documents;
- b. Acknowledging all conditions, local or otherwise, affecting the implementation of the Contract;
- c. Making an estimate of the facilities available and needed for the contract to be bid, if any; and
- d. Inquiring or securing Supplemental/Bid Bulletin(s) issued for the *[Name of the Project]*.

9. *[Name of Bidder]* did not give or pay directly or indirectly, any commission, amount, fee, or any form of consideration, pecuniary or otherwise, to any person or official, personnel or representative of the government in relation to any procurement project or activity.

10. In case advance payment was made or given, failure to perform or deliver any of the obligations and undertakings in the contract shall be sufficient grounds to constitute criminal liability for Swindling (Estafa) or the commission of fraud with unfaithfulness or abuse of confidence through misappropriating or converting any payment received by a person or entity under an obligation involving the duty to deliver certain goods or services, to the prejudice of the public and the government of the Philippines pursuant to Article 315 of Act No. 3815 s. 1930, as amended, or the Revised Penal Code.

IN WITNESS WHEREOF, I have hereunto set my hand this __ day of __, 20__ at _____, Philippines.

[Insert NAME OF BIDDER OR ITS AUTHORIZED REPRESENTATIVE]

[Insert signatory's legal capacity]

Affiant

[Jurat]

[Format shall be based on the latest Rules on Notarial Practice]

SECRETARY’S CERTIFICATE

I, _____, a duly elected and qualified Corporate Secretary of _____, a corporation duly organized and existing under and by virtue of the law of the _____, DO HEREBY CERTIFY, that:

I am familiar with the facts herein certified and duly authorized to certify the same;

At the regular meeting of the Board of Directors of the said Corporation duly convened and held on _____ at which meeting a quorum was present and acting throughout, the following resolutions were approved, and the same have not been annulled, revoked and amended in any way whatever and are in full force and effect on the date hereof:

RESOLVED, that _____ be, as it hereby is, authorized to participate in the bidding for “**Completion of the Lobby Area and Breakout Rooms of the UPOU International Convention Center**”, **Project Identification IB No. 25-01-001** by the **UP Open University** and that if awarded the project shall enter into a contract with the **UP Open University**; and in connection therewith hereby appoint _____, acting as duly authorized and designated representatives of _____, are granted full power and authority to do, execute and perform any and all acts necessary and/or to represent _____ in the bidding as fully and effectively as the _____ might do if personally present with full power of substitution and revocation and hereby satisfying and confirming all that my said representative shall lawfully do or cause to be done by virtue hereof;

- RESOLVED FURTHER THAT, the _____ hereby authorizes its President to:
- (1) execute a waiver of jurisdiction whereby the _____ hereby submits itself to the jurisdiction of the Philippine government and hereby waives its right to question the jurisdiction of the Philippine courts;
 - (2) execute a waiver that the _____ shall not seek and obtain writ of injunctions or prohibition or restraining order against the AFP or any other agency in connection with this project to prevent and restrain the bidding procedures related thereto, the negotiating of and award of a contract to a successful bidder, and the carrying out of the awarded contract.

WITNESS the signature of the undersigned as such officer of the said _____ this _____.

(Corporate Secretary)

ACKNOWLEDGMENT

SUBSCRIBED AND SWORN to before me this _____ day of _____, 20__ affiant exhibited to me his/her Government Issued ID No. _____ issued on _____ at _____, Philippines.

Notary Public
Until 31 December 20__
PTR No. _____
Issued at: _____
Issued on: _____
TIN No. _____

Doc. No. _____
Page No. _____
Book No. _____
Series of _____.

SPECIAL POWER OF ATTORNEY

I, _____, President of _____, a corporation incorporated under the laws of _____ with its registered office at _____, by virtue of Board Resolution No. _____ dated _____, has made, constituted and appointed _____ true and lawful attorney, for it and its name, place and stead, to do, execute and perform any and all acts necessary and/or represent _____ in the bidding of _____ as fully and effectively as corporation might do if personally present with full power of substitution and revocation and hereby confirming all that said representative shall lawfully do or cause to be done by virtue hereof.

IN WITNESS WHEREOF, I have hereunto set my hand this _____ day of _____, 20____ at _____.

Affiant

Signed in the Presence of:

ACKNOWLEDGMENT

REPUBLIC OF THE PHILIPPINES)
QUEZON CITY)SS.

BEFORE ME, a Notary Public for and in Quezon City, Philippines, this _____ day of _____, 20____, personally appeared:

<u>NAME</u>	<u>Government Issued ID NO.</u>	<u>ISSUED AT/ON</u>
_____	_____	_____
_____	_____	_____

known to me and known to be the same person who executed the foregoing instrument consisting of _____ () pages, including the page whereon the acknowledgments is written and acknowledged before me that the same is his free and voluntary act and deed and that of the Corporation he represents.

WITNESS MY HAND AND NOTARIAL SEAL, at the place and on the date first above written.

Notary Public
Until 31 December 20____
PTR No. _____
Issued at: _____
Issued on: _____
TIN No. _____

Doc. No. _____
Page No. _____
Book No. _____
Series of _____

NET FINANCIAL CONTRACTING CAPACITY

The computation of a prospective bidder's Net Financial Contracting Capacity (NFCC) must be at least equal to the ABC to be bid (PhP5,114,183.33), calculated as follows:

ABC: PhP5,114,183.33	Year 20__
Current Assets	
Minus: Current Liabilities	
Sub Total	
Multiplied by value of K	
Sub Total	
Minus: Value of outstanding services under ongoing contracts including awarded contracts yet to be started coinciding with the contract to be bid	
NFCC	

NFCC = [(current asset minus current liabilities) (15)] minus value of all outstanding or uncompleted portions of the projects under ongoing contracts including awarded contracts yet to be started coinciding with the contract to be bid.

NFCC = PhP _____

The values of the domestic bidder's current assets and current liabilities shall be based on the latest Audited Financial Statements submitted to the BIR.

Submitted by:

Name of Supplier / Distributor / Manufacturer

Signature of Authorized Representative

Date : _____

NOTE:

1. If Partnership or Joint Venture, each Partner or Member Firm of Joint Venture shall submit the above requirements.

JOINT VENTURE AGREEMENT

KNOW ALL MEN BY THESE PRESENTS:

That this JOINT VENTURE AGREEMENT is entered into by and between _____, of legal age, _____ owner/proprietor of _____ (civil status) and a resident of _____.

- and -

_____, of legal age, _____, owner/proprietor of _____ (civil status) _____ a resident of _____.

THAT both parties agree to join together their manpower, equipment, and what is need to facilitate the Joint Venture to participate in the Eligibility, Bidding and Undertaking of the here-under stated project to be conducted by the UP Open University.

NAME OF PROJECT

CONTRACT AMOUNT

That both parties agree to be jointly and severally liable for the entire assignment.

That both parties agree that _____ and/or _____ shall be the Official Representative of the Joint Venture, and is granted full power and authority to do, execute and perform any and all acts necessary and/or to represent the Joint Venture in the bidding as fully and effectively and the Joint Venture may do and if personally present with full power of substitution and revocation.

THAT this Joint Venture Agreement shall remain in effect only for the above stated Project until terminated by both parties.

Done this _____ day of _____, in the year of our Lord _____.

ACKNOWLEDGMENT

SUBSCRIBED AND SWORN to before me this _____ day of _____, 20__ affiant exhibited to me his/her Government Issued ID No. _____ issued on _____ at _____, Philippines.

Notary Public
Until 31 December 20____
PTR No. _____
Issued at: _____
Issued on: _____
TIN No. _____

Doc. No. _____
Page No. _____
Book No. _____
Series of _____.

BID FORM

Date : _____
Project Identification No. : _____

To: *[name and address of Procuring Entity]*

Having examined the Philippine Bidding Documents (PBDs) including the Supplemental or Bid Bulletin Numbers *[insert numbers]*, the receipt of which is hereby duly acknowledged, we, the undersigned, declare that:

- a. We have no reservation to the PBDs, including the Supplemental or Bid Bulletins, for the Procurement Project: *[insert name of contract]*;
- b. We offer to execute the Works for this Contract in accordance with the PBDs;
- c. The total price of our Bid in words and figures, excluding any discounts offered below is: *[insert information]*;
- d. The discounts offered and the methodology for their application are: *[insert information]*;
- e. The total bid price includes the cost of all taxes, such as, but not limited to: *[specify the applicable taxes, e.g. (i) value added tax (VAT), (ii) income tax, (iii) local taxes, and (iv) other fiscal levies and duties]*, which are itemized herein and reflected in the detailed estimates,
- f. Our Bid shall be valid within a period stated in the PBDs, and it shall remain binding upon us at any time before the expiration of that period;
- g. If our Bid is accepted, we commit to obtain a Performance Security in the amount of *[insert percentage amount]* percent of the Contract Price for the due performance of the Contract, or a Performance Securing Declaration in lieu of the the allowable forms of Performance Security, subject to the terms and conditions of issued GPPB guidelines¹² for this purpose;
- h. We are not participating, as Bidders, in more than one Bid in this bidding process, other than alternative offers in accordance with the Bidding Documents;
- i. We understand that this Bid, together with your written acceptance thereof included in your notification of award, shall constitute a binding contract between us, until a formal Contract is prepared and executed; and
- j. We understand that you are not bound to accept the Lowest Calculated Bid or any other Bid that you may receive.
- k. We likewise certify/confirm that the undersigned, is the duly authorized representative of the bidder, and granted full power and authority to do, execute and perform any and all acts necessary to participate, submit the bid, and to sign and execute the ensuing contract for the *[Name of Project]* of the *[Name of the Procuring Entity]*.

1. We acknowledge that failure to sign each and every page of this Bid Form, including the Bill of Quantities, shall be a ground for the rejection of our bid.

Name: _____

Legal Capacity: _____

Signature: _____

Duly authorized to sign the Bid for and behalf of: _____

Date: _____

CONSTRUCTOR'S ORGANIZATIONAL CHART FOR THE CONTRACT

Submit Copy of the Organizational Chart that the Constructor intends to use to execute the Contract if awarded to it. Indicate in the chart the names of the **All Key Personnel for the Project**.

Attach the required Proposed Organizational Chart for the Contract as stated above

Note: This organization chart should represent the "Constructor's Organization" required for the Project, and not the organizational chart of the entire firm.

CONTRACTOR'S LETTER-CERTIFICATE TO PROCURING ENTITY

[Date of Issuance]

Dr. PRIMO G. GARCIA

Chair, Bids and Awards Committee (BAC)

UP Open University

UPOU Headquarters, Los Baños, Laguna

Dear Sir:

Supplementing our Organizational Chart for the Contract, we have the honor to submit herewith, and to certify as true and correct, the following pertinent information:

1. That I/we have engaged the services of (Name of Employee/Key Personnel) , to be the (Designation) of the (Name of Contract) , who is a (Profession) with Professional License Certificate No. issued on and who has performed the duties in the construction of the Contracts enumerated in the duly filled Form .
2. The said Engineer/Employee/Key Personnel shall be designated by us as our (Designation) to personally perform the duties of the said position in the above-mentioned Project, if and when the same is awarded in our favor.
3. That said Engineer/Employee/Key Personnel shall employ the best care, skill and ability in performing his duties in accordance with the Contract Agreement, Conditions of Contract, Plans, Specifications, Special Provisions, and other provisions embodied in the proposed contract.
4. That said Engineer/Employee/Key Personnel shall be personally present at the jobsite to supervise the phase of the construction work pertaining to this assignment as (Designation) , all the time.
5. That, in order to guarantee that said Engineer/Employee/Key Personnel shall perform his duties properly and be personally present in the Job Site, he is hereby required to secure a certificate of appearance for the Procuring Entity Engineer/Authorized Representative at the end of every month.

That, in the event that I/we elect or choose to replace said (Designation) with another Engineer/Employee/Key Personnel, the Procuring Entity will be accordingly notified by us in writing at least twenty one (21) days before making the replacement. We will submit to the Procuring Entity, for prior approval, the name of the proposed new (Designation) , his qualifications, experience, and list of projects undertaken and other relevant information.

6. That any willful violation on my/our part of the herein conditions may prejudice my/our standing as a reliable contractor in future bidding of the Procuring Entity.

Very truly yours,

(Name and Signature of Authorized Representative of Bidder)

CONCURRED IN:

(Name and Signature of Employee/Key Personnel)

(Address)

QUALIFICATION OF KEY PERSONNEL PROPOSED TO BE ASSIGNED TO THE CONTRACT

Bidder's Name: _____

Bidder's Address: _____

		Project Architect/Civil Engineer	Safety Officer/Engineer	General Foreman				
Name								
Address								
Date of Birth								
Employed Since								
Experience								
(a) Total Experience (Years)	Required							
	Actual							
(b) Experience in Similar Project (Years)	Required							
	Actual							
Previous Employment								
Education								
PRC Registration & License/ Accreditation/ Certification (as required)								

Note: This form is applicable to all required List of Key Personnel for the Contract to Bid

Submitted by: _____

(Printed Name & Signature)

Designation: _____

Date: _____

BIO-DATA OF KEY PERSONNEL

Give the detailed information of the following personnel who are scheduled to be assigned as full-time field staff for the project. **Fill out a form for each person.**

- Authorized Managing Officer / Representative

- Sustained Technical Employee

1. Name: _____

2. Date of Birth: _____

3. Nationality: _____

4. Education and Degrees: _____

5. Specialty: _____

6. Registration: _____

7. Length of Service with the Firm: _____ Year from _____ (months) _____ (year)
to _____ (months) _____ (year)

8. Years of Experience: _____

9. If Item 7 is less than ten (10) years, give name and length of service with previous employers for a ten (10)-year period (attached additional sheet/s), if necessary:

Name and Address of Employer	Length of Service
_____	_____ year(s) from _____ to _____
_____	_____ year(s) from _____ to _____
_____	_____ year(s) from _____ to _____

10. Experience:

This should cover the past ten (10) years of experience. (Attached as many pages as necessary to show involvement of personnel in projects using the format below).

1. Name: _____

2. Name and Address of Owner: _____

3. Name and Address of the Owner's Engineer: _____
(Consultant)

4. Indicate the Features of Project (particulars of the project components and any other particular interest connected with the project): _____

5. Contract Amount Expressed in Philippine Currency: _____

6. Position: _____

7. Structures for which the employee was responsible: _____

8. Assignment Period: from _____ (months) _____ (years)
: to _____ (months) _____ (years)

Name and Signature of Employee/Key Personnel

It is hereby certified that the above personnel can be assigned to this project, if the contract is awarded to our company.

(Place and Date)

(Bidder's Authorized Representative)

post of (Designation) therefor, if the contract is awarded to him since I understand that to do so will be a sufficient ground for my disqualification as (Designation) in any future (Name of the Procuring Entity) bidding or employment with any Contractor doing business with the (Name of the Procuring Entity) .

(Signature)

DRY SEAL

Republic of the Philippines)
_____) S.S.

SUBSCRIBED AND SWORN TO before me this _____ day of _____ 20__ affiant exhibiting to me his Government Issued ID No. _____ issued on _____ at _____.

Notary Public
Until December 31, 20__

Doc. No. _____;
Page No. _____;
Book No. _____;
Series of _____;

List of contractor’s major equipment units, which are owned, leased, and/or under purchase agreements, supported by proof of ownership or certification of availability of equipment from the equipment lessor/vendor for the duration of the project, as the case may be:

A. Equipment	Minimum Quantity	Available Quantity
1. Grinder	Min. 2 units	
2. Tile Cutter	Min. 2 units	
3. Welding Machine	Min. 2 units	
4. Compressor	Min. 1 unit	
B. Others	No. of Units	
1. PPE (Personal Protective Equipment) (includes hard hat, safety vest, safety shoes, safety harness, safety gloves)	Min. of 15pcs per item except safety harness (5pcs only)	

Note: This statement shall be supported with Proof of ownership such as Certified copy of the Official Receipt of each item listed or an Affidavit of ownership.

Certified Correct:

Signature Over Printed Name of the Authorized Representative

**LIST OF CONTRACTORS EQUIPMENT, OWNED OR LEASED AND/OR UNDER
PURCHASE AGREEMENTS**

Bidder's Name: _____

Bidder's Address: _____

Description	Model/Year	Capacity/ Performance/Size	Plate No.	Motor No./ Body No.	Location	Condition	Proof of Ownership/ Lessor or Vendor
A. Owned							
i.							
ii.							
iii.							
iv.							
v.							
B. Leased							
i.							
ii.							
iii.							
iv.							
v.							
C. Under Purchase Agreements							
i.							
ii.							
iii.							
iv.							

List of minimum equipment required for the Project:

Submitted by : _____

(Printed Name & Signature)

Designation : _____

Date : _____

CASH FLOW BY QUARTER AND PAYMENT SCHEDULE

PARTICULAR	% WT.	1 ST QUARTER	2 ND QUARTER	3 RD QUARTER	4 TH QUARTER
ACCOMPLISHMENT					
CASH FLOW					
CUMULATIVE ACCOMPLISHMENT					
CUMULATIVE CASH FLOW					

SUBMITTED BY:

Name of Bidder

(Printed Name and Signature of Authorized Managing Officer)

Date

_____ Date

AFFIDAVIT OF SITE INSPECTION

This is to certify that this Company, through its authorized representative, _____, has conducted the inspection of the site for the project “_____” located at UP Open University Headquarters, Los Baños, Laguna, on this _____ day of _____ 20__, in connection with our desire to participate in the bidding for the above project.

(Printed Name & Signature of Bidder)

ACKNOWLEDGMENT

SUBSCRIBED AND SWORN to before me this _____ day of _____, 20__ affiant exhibited to me his/her Government Issued ID No. _____ issued on _____ at _____, Philippines.

Notary Public
Until 31 December 20__
PTR No. _____
Issued at: _____
Issued on: _____
TIN No. _____

Doc. No. _____
Page No. _____
Book No. _____
Series of _____.

Sealing and Marking of Bids:

Submission of hard copies to the BAC Secretariat Address:

One Original Copy for the Technical Components and Financial Components

PROCEDURE:

1. The Technical Components (TC) of the Bid should be enclosed in envelope and must be labelled, sealed and signed as follows:

COMPLETION OF THE LOBBY AREA AND BREAKOUT ROOMS OF THE UPOU
INTERNATIONAL CONVENTION CENTER – TECHNICAL COMPONENT

[NAME AND ADDRESS OF THE BIDDERS]
BIDS AND AWARDS COMMITTEE SECRETARIAT
UP OPEN UNIVERSITY
UPOU HEADQUARTERS, LOS BAÑOS, LAGUNA
REFERENCE NO. IB No. 25-01-001
“DO NOT OPEN BEFORE 28 January 2025, 2:00 PM”

2. The Financial Components (FC) of the Bid should be enclosed in another envelope and must be sealed and signed;

COMPLETION OF THE LOBBY AREA AND BREAKOUT ROOMS OF THE UPOU
INTERNATIONAL CONVENTION CENTER – FINANCIAL COMPONENT

[NAME AND ADDRESS OF THE BIDDERS]
BIDS AND AWARDS COMMITTEE SECRETARIAT
UP OPEN UNIVERSITY
UPOU HEADQUARTERS, LOS BAÑOS, LAGUNA
REFERENCE NO. IB No. 25-01-001
“DO NOT OPEN BEFORE 28 January 2025, 2:00 PM”

3. The TC and FC envelopes should be enclosed in one mother envelope and must be labelled, sealed and signed as follows:

COMPLETION OF THE LOBBY AREA AND BREAKOUT ROOMS OF THE UPOU
INTERNATIONAL CONVENTION CENTER

[NAME AND ADDRESS OF THE BIDDERS]
BIDS AND AWARDS COMMITTEE SECRETARIAT
UP OPEN UNIVERSITY
UPOU HEADQUARTERS, LOS BAÑOS, LAGUNA
REFERENCE NO. IB No. 25-01-001
“DO NOT OPEN BEFORE 28 January 2025, 2:00 PM”

Republic of the Philippines



Government Procurement Policy Board